Davis

EQUIPMENT CATALOG NO. 20



Davis-Lynch, LLC

Equipment Catalog No. 20

For direct access to any of the pages below, click on the title

Table of Contents (Page numbers indicated refer to actual catalog pages, not pages of CD presentation.)

New from Davis		Screw-In Equipment	10-11
Type 512-CAF Convertible Down/Up-Jet Auto-Fill Float Shoe	1	Latch-In Equipment	10-11
Davis Manual-Fill Float Shoes		Special Inner-String Cementing Equipment	11
Float Shoe Type 500-PVTS	2-3	Davis Extended Reach Equipment	
Down-Jet Float Shoe Type 501-PVTS	2-3	Flotation Collar	12-13
Double-Valve Down-Jet Float Shoe Type 501 DV-PVTS	2-3	Davis Cementing Enhancement Devices	
Guide Shoes Types 600 and 601	2-3	Non-Welded Centralizer	14
Down-Jet Set Shoe with Lug Nose Type "S"	2-3	Close-Tolerance Bow Spring Centralizer	14
Ribbed Down-Jet Float Shoe	2-3	Non-Welded Semi-Rigid Centralizer	14-15
Needle Nose Float Shoe	2-3	"NW" Type Centralizer Dimension and Performance Data	14
Mule Shoe Type 610	3	Non-Welded Turbolizer	15
Texas Pattern Casing Shoes Types 800 and 800ST	3	Cement Basket	15
Davis Manual-Fill Float Collars		"SR" Type Semi-Rigid Centralizer Dimension and Performance Data	15
Float Collar Type 700-PVTS	4	Non-Welded Rigid Centralizer	16
Lock-Down Anti-Rotation Plug System Type LAP	4	Stop Collars	16
Lock-Down Anti-Rotation Plug System Type LAP/N Combination Brush/Plug	5	Spherical Stand-Off Device	16
Davis Self-Filling Float Shoes and Float Collars		"R" Type Rigid Centralizer Dimension Data	16
Pump Convert PVTS Automatic Fill-Up Shoes and Collars	5	Solid Body Flow Diverter	17
Drop Ball Convert Automatic Fill-Up Shoes and Collars	6	Centralizer Application Analysis	17
Drop Ball Convert Differential Fill-Up Shoes and Collars	6	Davis Stage Cementing Collars and Equipment	
Standard Stock Float Equipment Data	7	Type 778 MC Mechanical Stage Cementing Collar	18
Davis Insert Float Valves		Type 777 HY Hydraulic-Opening Stage Cementing Collar	19
Insert Float Valve Type 900 F	7	Plug Systems for Two- and Three-Stage Cementing	20-21
Insert Float Fill-Up Valve Type 904 F	7	Specification Tables for Type 778 MC and Type 777 HY	22
Davis Thread Compounds		Packer Stage Cementing Collar Type 778-100	23-25
Thread Locking Compound	7	Davis Inflatable Packers	
Thread Sealing and Lubricating Compounds	7	Inflatagrip Longseal Packers	26
Non-Metallic Thread Compound	7	Packers with Continuous Reinforcing	27
Super-Seal Thread Compound	7	Inflatagrip® Feature	27
Davis Inner-String Cementing Equipment		Integral Casing Packer	28
Tag-In Equipment	8-9	Packer Selection Data	28
Pack-Off Head Assemblies	8-9	Fill and Circulate Tool	
Inner-String Adapters	9		
Latch-Down Wiper Plug	9	Visit our website at www.davis-lynch.com	

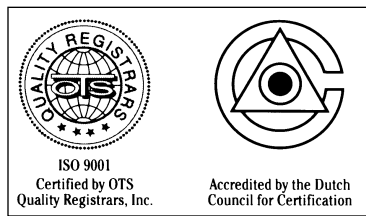

NEW from Davis

Davis Type 512-CAF Convertible Down/Up-Jet Auto- Fill Float Shoe*

Consistent with the Davis tradition of offering new technology to meet operators' requirements, we have recently introduced this shoe to the industry. The unique Type 512-CAF shoe offers several design features/benefits to assist the operator in meeting objectives to successfully run casing to bottom, and carry out cementing operations. The field applications for this shoe range from close tolerance liners to full casing strings run to surface, or landed in a sub-sea wellhead.

The list of features/benefits that this shoe provides for operators includes:

- The ability for casing/liner to self-fill as it is being run into the hole. This

self-filling action can significantly reduce surge pressures on the formation, and also reduce running time for casing/liner. The result of this can be substantial savings in rig time, and a reduction in the amount of drilling fluid lost during the casing/liner run. The Type 512-CAF shoe is available with several options for flow through area for the self-filling feature. (See Fig. 1).

- The ability to circulate through down jets/center of shoe while running in the hole. This provides a means of washing casing/liner to seat if required. (See Fig. 2).

- Once converted, the ability for cement to be pumped through up-jets for optimum cement placement. (See Fig. 3).

- Double valve assembly in shoe allowing for redundancy to prevent cement u-tube after completion of cementing operations.

- Ball seat for conversion of shoe can serve a multi-purpose function. Conversion pressure can be adjusted to allow for setting hydraulic type liner hangers, prior to converting shoe at higher-pressure value. This allows for single ball to be utilized

rather than multiple balls as in previous systems.

- Single ball conversion on liner applications also allows for greater flow through area for self-filling of casing/liner. This allows for maximum surge reduction, and minimizes potential of self-filling feature being compromised by solids encountered in the well bore.

- Large flow through area for self-filling action makes the Type 512-CAF shoe optimum for close tolerance applications with casings being landed at the sub-sea wellhead, in deep water drilling environments.

- Shoe has been drilled out with PDC bits successfully on several applications.

- Components of Type 512-CAF shoe can also be installed into a collar if desired, and run together with a guide shoe.

The Type 512-CAF shoe has been successfully used on numerous wells to date. Available in a full range of casing sizes, contact your Davis representative for full information.

*Patent Pending

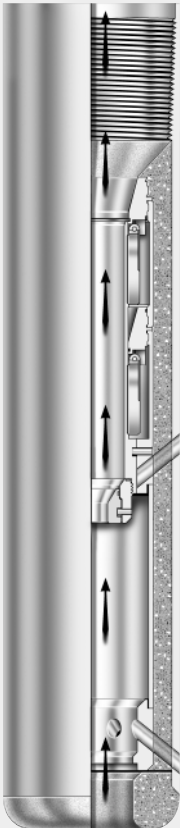

Fig. 1
Casing self-filling as it is
run in the hole

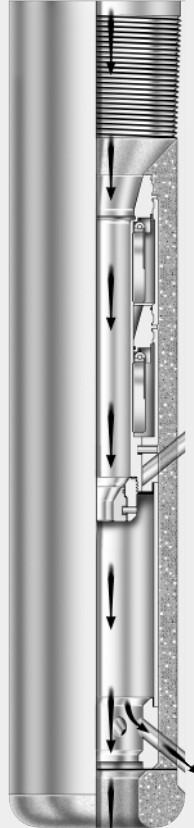

Fig. 2
Circulating through down-jets/
center of shoe

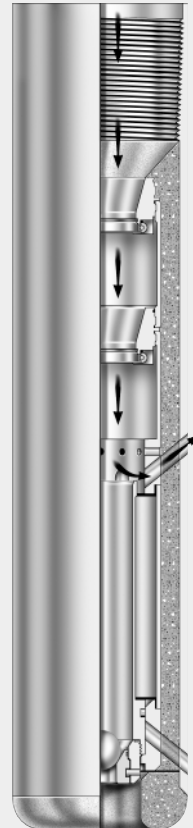
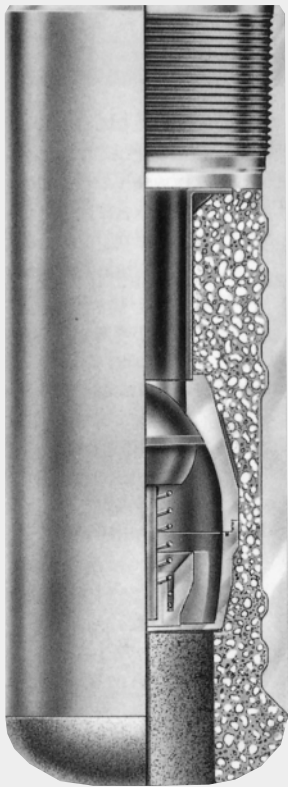
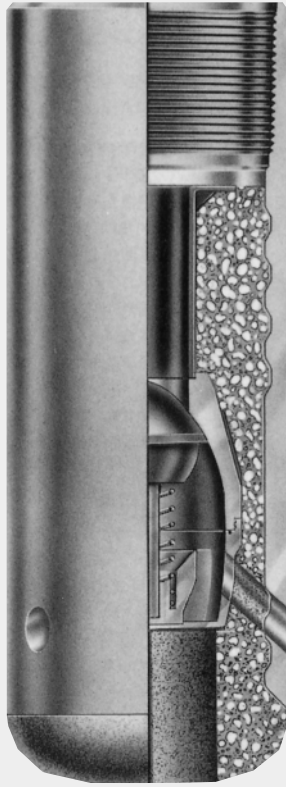

Fig. 3
Shoe converted, valves actuated.
Cementing through up-jets.



Type 500-PVTS



Type 501-PVTS

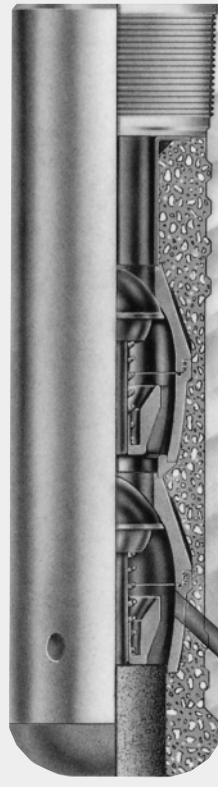

Type 501 DV-PVTS



Type 600



Type "S" Set Shoe

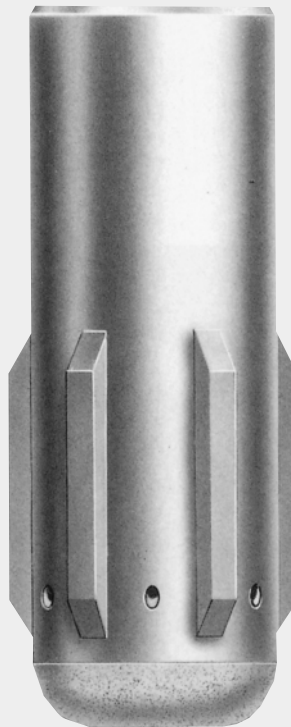

Ribbed Down-Jet
Float Shoe

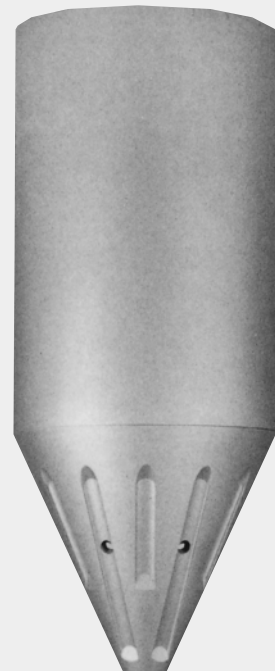

Needle Nose
Float Shoe

Davis Manual-Fill Float Shoes

Davis manual-fill float shoes and float collars are simple in design and operation. They have been engineered and manufactured to withstand the high temperatures encountered and the high pressures created by differences in fluid columns when floating, landing, and cementing strings of casing.

Davis' standard design manual-fill float shoes and float collars are manufactured with the Davis PVTs valve. This valve is a spring-actuated, plunger-type, one-way check valve. It is designed to withstand high temperatures and large volumes of fluids pumped at high flow rates. It also provides an effective seal under both high- and low-pressure conditions when casing is run and cemented in either the vertical or horizontal position.

The valve housing and closure element are made with a phenolic material. High strength concrete is the compound that molds the valve in the machined housing to form a strong singular unit. Despite the high compressive strength of the concrete, and the shear strength of the valve, Davis float shoes and collars are easily drilled with conventional or PDC bits.

Because of its proven performance qualities, the PVTs valve is used in all manual-fill Davis float equipment including double-valve shoes and collars, and all inner-string cementing equipment including the tag-in, screw-in, and latch-in designs.

Since Davis float shoes and float collars are usually manufactured from steel that has a greater wall thickness than the pipe body of the casing string they are run in, they normally have burst and collapse resistance greater than the casing string.

Float Shoe Type 500-PVTs

This shoe features a strong, rounded concrete nose that aids in guiding the casing string to bottom and incorporates the PVTs back-pressure valve assembly. These features make this Davis shoe highly preferred for conventional cementing jobs.

Down-Jet Float Shoe Type 501-PVTs

Along with all the features incorporated into the Type 500-PVTs float shoe, the popular Type 501-PVTs model features properly drilled and angled down-jet ports. The even distribution of fluid through these raised ports delivers to the user several advantages, including the added

assurance that circulation can be established when casing becomes plugged during running or is landed on bottom. The angle of the ports assists if casing has to be washed to bottom, and the spacing of the ports assists in breaking up or preventing cement channeling.

Double-Valve Down-Jet Float Shoe Type 501 DV-PVTs

For additional protection, choose this shoe which combines the maximum security of a unitized double check valve along with all the benefits inherent in the Type 501-PVTs.

Guide Shoes Types 600 and 601

The rounded design of the concrete noses of these Davis shoes assists in guiding the casing string into the hole and safely to the bottom. Both have flat-finished concrete tops to provide strong surfaces for landing cement plugs. The Type 600 (shown) has a single fluid outlet through the nose while the Type 601 (not shown) has down-jets which deliver the efficient washing action, cement slurry distribution and other benefits of the Type 501-PVTs.

Down-Jet Set Shoe with Lug Nose Type "S"

This Davis shoe comes with a special drillable lug nose for use when casing is run as a liner, lowered on drill pipe and set on bottom. When bottom is contacted, the nose piece will prevent the casing from rotating when the drill pipe is released from the liner. This lug nose design can also be incorporated into self-filling shoes.

Ribbed Down-Jet Float Shoe

The externally raised ribs of this shoe aid in centering the casing at

bottom and promote more even distribution of cement to reduce the risk of channeling. Ribbed float collars are also available.

Needle Nose Float Shoe

Field-proved for over 20 years, the Davis Needle Nose Float Shoe has provided operators with an aid to run casing in adverse conditions. With its tapered aluminum nose, it has been extremely effective for running casing through tight spots, different geometric sections in the wellbore, and previous casing strings that have been damaged.

It incorporates down-jet ports that create turbulent flow at the shoe for washing, conditioning, or cementing. The Needle Nose Shoe can be equipped with the Davis Type PVTs valve, which has been proven to meet or exceed API RP 10 F category III C., or with a self-filling type valve.

Mule Shoe Type 610

The Davis Mule Shoe is used when the running of casing is hindered by hole conditions. When the shoe encounters a ledge in the wellbore, for example, it is rotated so that the fluid under pump pressure washes the ledge off. The shoe can also be used to facilitate getting over or by obstacles in the hole.

Texas Pattern Casing Shoes Types 800 and 800ST

These types of casing shoes are popular for use in reinforcing the end of the casing on shallow strings. They help the casing to run past bridges, and they provide maximum circulation through the casing. They are available with smooth-surface or saw-tooth bottoms.

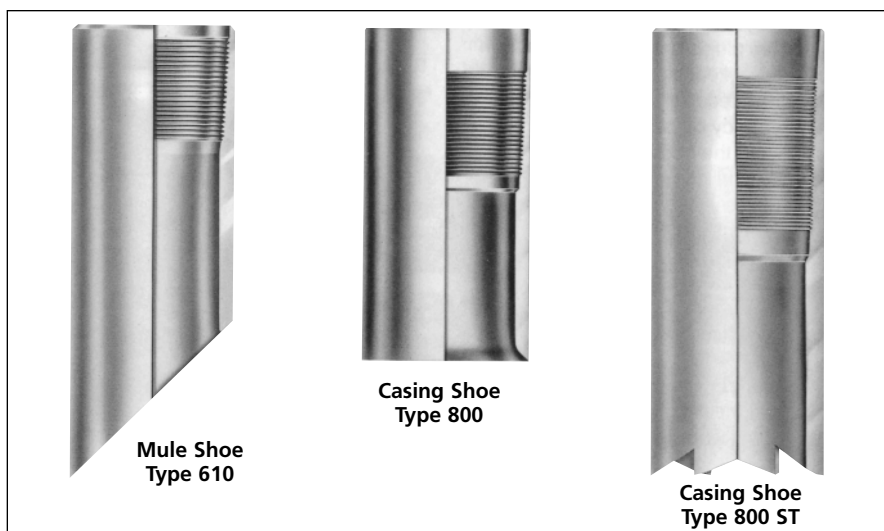

Davis Manual-Fill Float Collars

Float Collar Type 700-PVTS (Fig. 1, below)

This Davis collar comes equipped with a flat concrete surface and load distributor plate for landing and sealing cement plugs. It normally is offered with pin and box thread connections, but it is also available with double-box connections. Both of these designs embody the positive-seal, PDC drillable Davis PVTS spring-operated plunger-type valve molded in place with high strength concrete.

When a back-pressure valve is not desired or required in a float collar, Davis has available the Type 701 Baffle Collar (not shown). This collar allows fluid flow in either direction and provides a strong concrete surface to land and seal cement plugs. It is often run in tandem with the Davis Type 501 DV-PVTS double-valve, down-jet float shoe.

Lock-Down Anti-Rotation Plug System Type LAP (Surface launch and sub sea launch)*

Available for both surface launch and sub sea launch applications, Davis offers the Type LAP plug system. The Type LAP system incorporates our first generation of mechanism to prevent plug rotation while drilling out. This system is still used on some surface launch applications

involving specialty float equipment (such as auto-fill types), and is available through a joint venture with BJ Services Co. for sub sea applications. BJ Services Co. has incorporated the Davis Type LAP mechanism into their respective sub sea launch plugs, so the BJ plugs can be run with Davis Type LAP float collars (Fig. 2, below), and provide an effective means to prevent rotation while drilling out.

The system features a float collar that incorporates a threaded type receiver to receive a collet type insert. A bottom plug with collet insert on bottom, and threaded type receiver on top of plug. The top plug features a collet type insert on the bottom end. The collet feature allows for the bottom plug to latch into the float collar, as well as for the top plug to latch-in to the bottom plug. Once latched in, right hand rotation during drill out tightens up the engagement of the plugs and collar, with the threaded profiles on the collet and receiver. Some notable features/benefits are:

- Once engaged the latch-in design

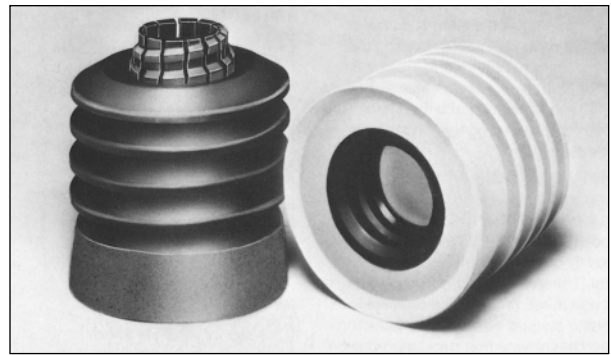

Lock-Down/Anti-Rotation Top and Bottom Cementing Plugs

prevents plugs from becoming disengaged by pressure acting on the plugs from below, or being mechanically disengaged during the drill-out process. A significant improvement over other designs that only mesh against rotation, this lock-down feature is unique to Davis.

- Five-wiper premium quality plugs provide for most efficient casing wiping.
- Type LAP collars and plugs are field proven for easy drill out with PDC bits.
- System allows for use of multiple bottom plugs or no bottom plugs if desired.
- Davis float shoes are also available with the Type LAP insert upon request.

*US Patent No. 5,234,052

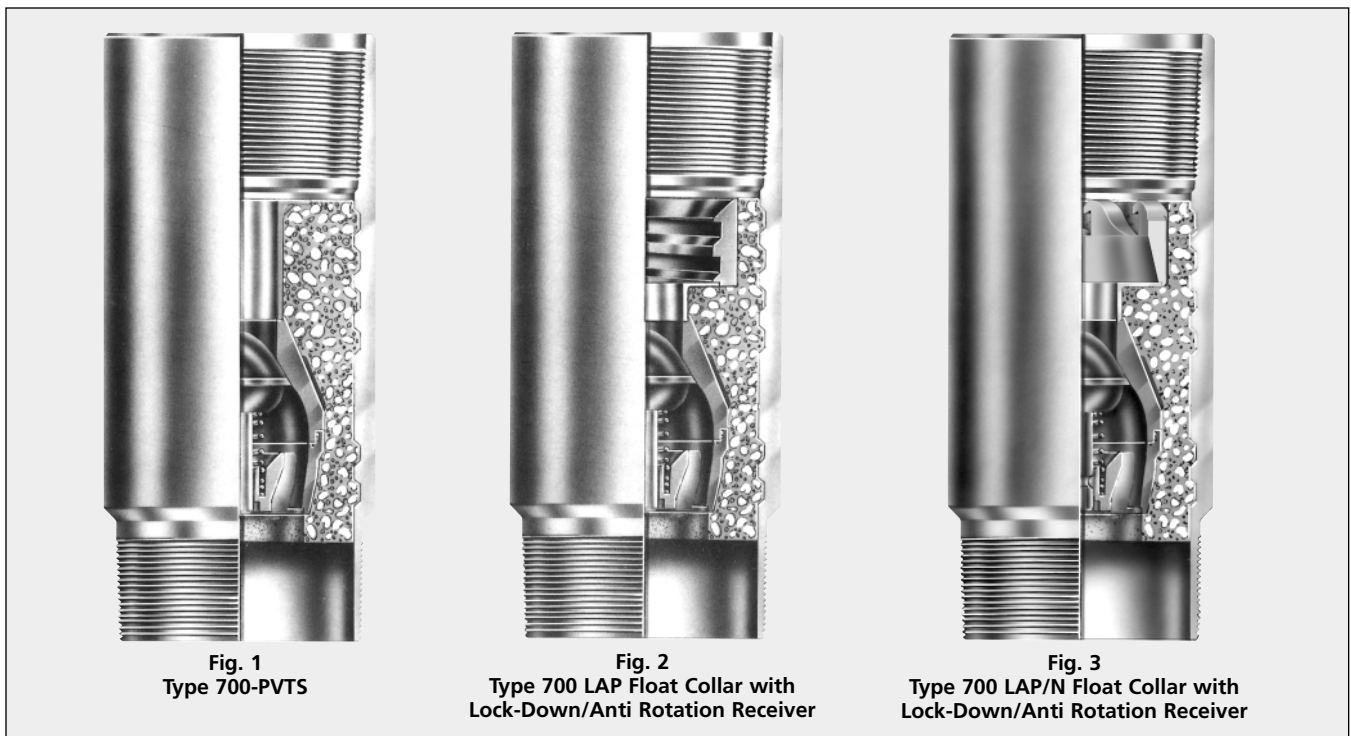

Fig. 1
Type 700-PVTS

Fig. 2
Type 700 LAP Float Collar with
Lock-Down/Anti Rotation Receiver

Fig. 3
Type 700 LAP/N Float Collar with
Lock-Down/Anti Rotation Receiver

*US Patent No. 5,842,517

Lock-Down Anti-Rotation Plug System Type LAP/N (Surface launch)*

Available for surface launch applications, Davis offers the Type LAP/N plug system. This system incorporates our latest generation of mechanism to prevent plug rotation while drilling out. The system features a float collar (Fig. 3, opposite page) with a heavy duty "tooth like" insert incorporated, a bottom cementing plug with heavy duty inserts incorporated on top and bottom, as well as a top plug with a heavy duty insert incorporated on bottom. The unique angled tooth design of the system allows for easy engagement between plug and collar, as well as between plugs. Notable features/benefits are:

- Once engaged the angled tooth

design prevents plugs from becoming disengaged by pressure acting on the plugs from below, or being disengaged during the drill-out process. A significant improvement over other designs that only mesh against rotation, this lock-down feature is unique to Davis.

- Five-wiper premium quality plugs provide for most efficient casing wiping.
- Type LAP/N collars and plugs are field proven for easy drill out with PDC bits.
- System allows for use of multiple bottom plugs or no bottom plugs if desired.

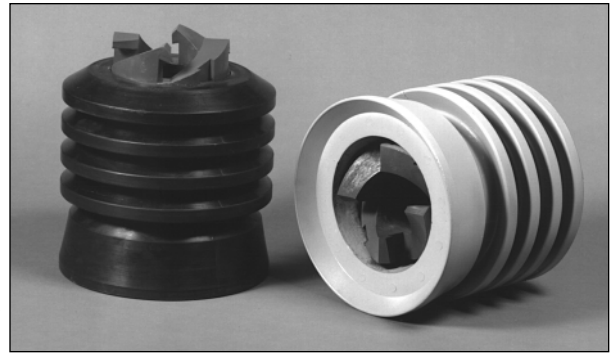

Lock-Down/Anti-Rotation Plugs Type LAP/N (Surface Launch)

- Davis float shoes are also available with the Type LAP/N insert upon request.

Davis Combination Brush/Plug**

An alternative to more typical well bore clean-outs, the Davis Combination Brush/Plug can save operators time and associated costs, by eliminating the requirement to run a work string/casing scraper on some applications. Available for several sizes of production casings, contact your Davis representative for more information.



* US Patent 5,842,517

** Patent Pending

Davis Self-Filling Float Shoes and Float Collars

Davis offers three types of self-filling equipment: the pump converted, PVTS valve equipped automatic-fill, the drop ball converted automatic-fill, and the drop ball converted differential-fill. All three types are simple in design to give top-quality performance.

Pump Convert PVTS Automatic Fill-Up Shoes and Collars

The Davis Type 505 AD-PVTS automatic fill-up shoe and the Davis Type 705 A-PVTS automatic fill-up collar utilize the proven Davis PVTS valve in self-filling equipment. The shoe and collar offer a fixed radial area that allows fluid to enter the casing and seek its own height. This action lowers surge pressures on formations to a minimum, reduces casing running time and, the chances of it sticking are lessened. Casing can be circulated at any time, with low rates, without converting the valve from the fill-up to the back-pressure mode.

Conversion from the fill-up to the back-pressure mode can be accomplished at any time while casing is being run by introducing a pre-determined flow rate to the equipment. Furthermore, if at casing running time it is determined that self-filling equipment is not desirable, the valve can be converted by manually forcing the plunger to its fully open position and removing the three retaining balls. Doing this requires filling the casing from the top as it is run.

Once conversion is carried out, all

the benefits of the proven Davis PVTS valve are realized, including PDC bit drillability and high pressure and temperature ratings.



Davis Self-Filling Float Shoes and Collars—cont.

Drop Ball Convert Automatic Fill-Up Shoes and Collars

The Davis Type 505 AF automatic fill-up shoe and the Davis Type 705 AF automatic fill-up collar allow maximum filling of the casing while it is being run in the hole, with the fluid entering the casing free to seek its own level. The filling action reduces casing running time and lowers surge pressures on formations to a minimum. Provided the conversion ball has not been dropped, casing can be circulated at any time without affecting the fill-up operation.

Drop Ball Convert Differential Fill-Up Shoes and Collars

The Davis Type 506 differential fill-up shoe and the Davis Type 706 differential fill-up collar allow optimum, metered filling of the casing, while it is being run in the hole. This filling action reduces casing running time, lowers surge pressures on formations, and minimizes the possibility of sticking. Providing the conversion ball has not been dropped, casing can be circulated at any time without affecting the fill-up operation.

Both the differential and the automatic fill-up equipment can be converted from the fill-up to the back-pressure mode at anytime during the casing run by dropping the weighted ball furnished with each piece. After allowing sufficient time for the ball to reach the equipment, conversion can be achieved by applying approximately 500 psi of pump pressure. If both a shoe and collar are present in the casing string, the same ball will convert both pieces in two "like-but-separate" actions.

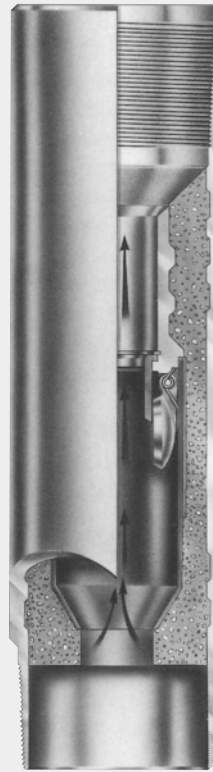

Running In
Type 705 AF

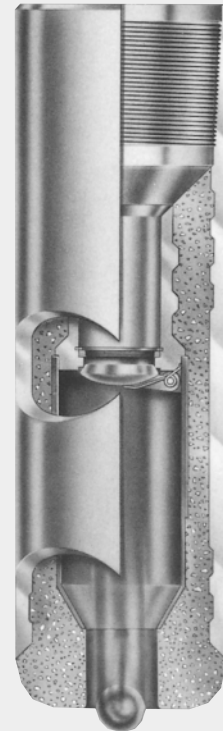

Valve Actuated
Type 505 AF

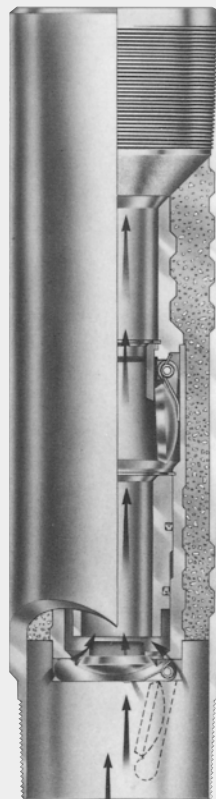

Running In
Type 706

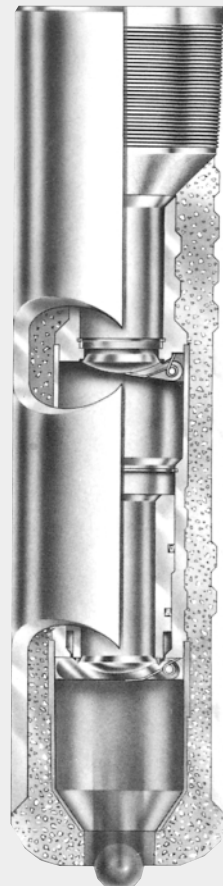

Valve Actuated
Type 506

Data for Davis Standard Stock Float Equipment manufactured from K-55 grade material and threaded with API Round-8 or Buttress Connections

Nominal Casing Size (Inches)	Weight Range (Lbs/Ft)	O.D. (Inches)	I.D. (Inches)	Burst (PSI)	Collapse (PSI)
4-1/2	9.5–13.5	5.000	4.031	9,300	9,600
5	11.5–21.0	5.563	4.439	9,720	9,950
5-1/2	14.0–23.0	6.050	4.950	8,750	9,050
7	23.0–38.0	7.656	6.276	8,650	9,000
7-5/8	20.0–39.0	8.500	6.969	8,650	9,000
8-5/8	24.0–44.0	9.625	8.017	8,000	8,400
9-5/8	32.3–53.5	10.625	8.921	7,700	8,100
10-3/4	32.7–55.5	11.750	10.050	6,950	7,350
11-3/4	38.0–65.0	12.750	11.000	6,600	7,000
13-3/8	48.0–72.0	14.375	12.615	5,850	5,850
16	65.0–109.0	17.000	15.250	4,950	4,250
18-5/8	87.5–117.5	20.000	17.755	5,400	5,050
20	94.0–133.0	21.000	19.125	4,250	3,150

Standard stock Davis Float Equipment meets or exceeds the burst and collapse ratings of N-80 Grade Casing for most weights within the range shown for each size.

NOTE: All burst and collapse pressure ratings are calculated in accordance with API Bulletin 5C3, Sixth Edition, October 1, 1994.

Davis Insert Float Valves

Insert Float Valve Type 900 F

The Davis Insert Float Valve Type 900 F is available for use in wells of moderate depth using API 8 round short thread or buttress casing.

Davis Insert Fill-Up Valve Type 904 F

Like the Type 900 F, the Davis Insert Fill-Up Valve Type 904 F is available for use in moderate depth wells, using API 8 round short-thread or buttress casing. This valve allows continuous fill of the casing as it is run into the hole. A drop-ball converts the 904 F into a conventional back-pressure valve.

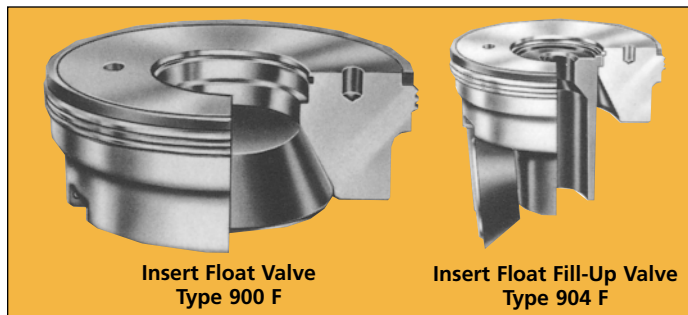

Davis Thread Compounds

Davis-Lock Thread Locking Compound

The Davis-Lock thread locking compound is a strong epoxy-based compound for use on all threaded connections to prevent back-off and loosening of joints. The one-pound kit contains the base, catalyst and applicator.

Davis API Modified Thread Compound

This Davis thread compound conforms to the specifications of API Bulletin 5A2. It is recommended for use on casing, tubing, and in line pipe.

Davis Non-Metallic Thread Compound

This Davis thread compound has been formulated as an environmentally safe replacement for API modified thread compound that will meet

or exceed the listed performance objectives in API Bulletin 5A2.

Davis Super-Seal Thread Compound

Davis developed the Super-Seal thread compound to provide long-lasting, high pressure sealing on all API threaded joints, especially tubing

and casing. The compound contains molydisulfide and TFE resin for a high-pressure seal. Joints coated with Davis Super-Seal hold better and make up easier with less torque and still break clean without damage.

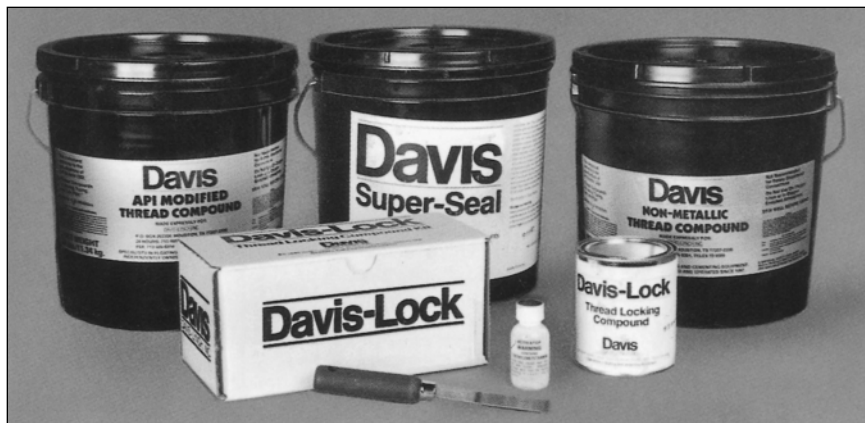

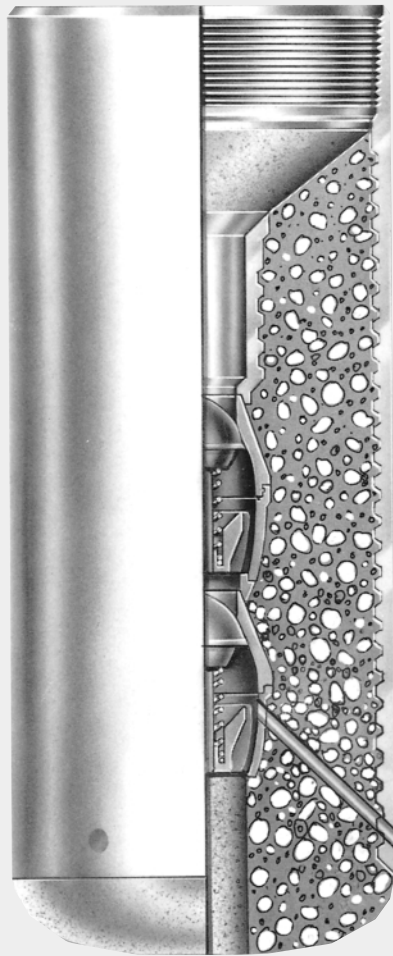
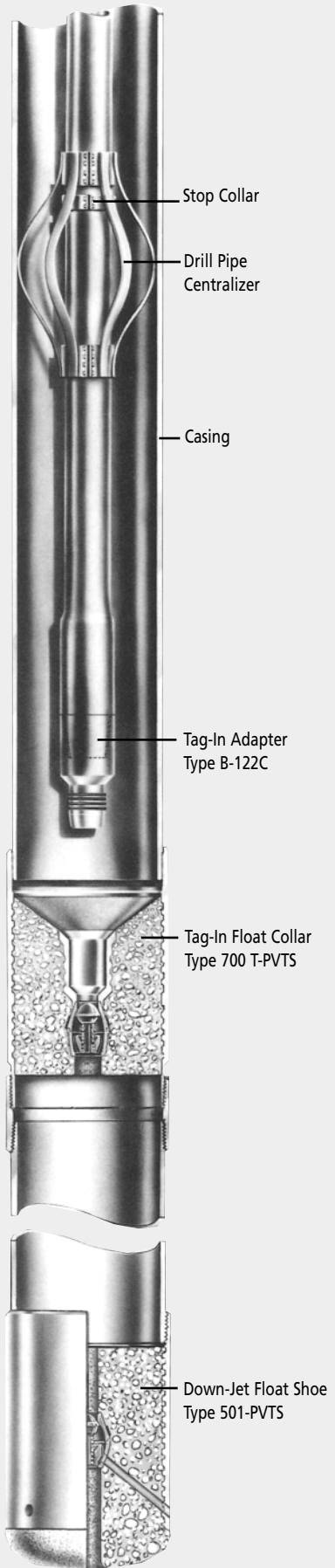

Type 501 DVT-PVTS

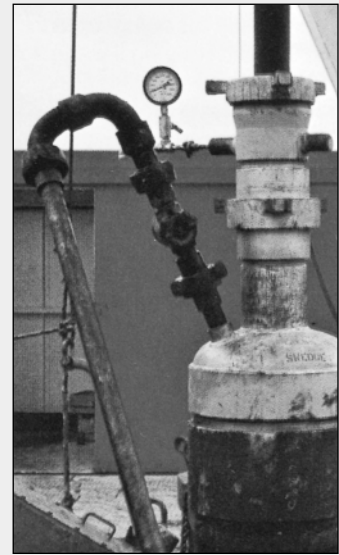

Pack-Off Head Assembly

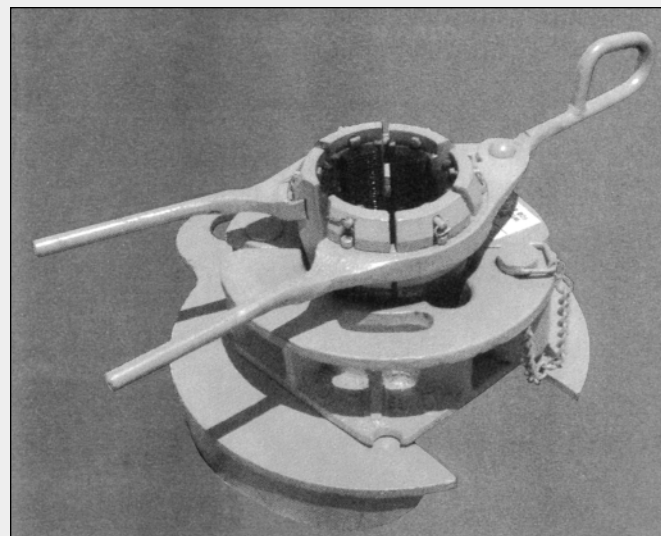

Drill Pipe Bowl and Slips

Davis Inner-String Cementing Equipment

Excellent cement jobs at reduced costs have boosted inner-string cementing equipment to the forefront of operator popularity. Davis was among the first to offer the inner-string systems, and continues today to have the most complete line of systems available in the industry.

Davis equipment is designed with a taper in the top of the concrete to guide the adapter on the bottom of the inner-string into the receiver incorporated in the float shoe or collar. All three styles of adapter-to-receiver adjoinments engage dual-seal mechanisms to prevent fluid leakage. The primary seal consists of elastomer seals compressed in a smooth bore. The 45° bearing face effected when the adapter and receiver adjoin creates the secondary seal.

Davis offers three proven systems for inner-string cementing: the Tag-In system, the Screw-In system, and the Latch-In system. The equipment used in these systems can be manufactured in virtually any size and thread, and as single or double-valve float shoes (with or without ports), float collars, and baffle collars.

An option available when ordering Davis inner-string equipment is a latch-down wiper plug. This plug follows the cement and wipes the drill pipe. Once properly latched down, the plug and latch mechanism act to check back pressure, giving additional assurance that cement will be retained in the desired position and the inner-string (drill pipe) can be immediately pulled out of the hole.

Davis is the only company that stocks in local inventories all the accessory items required to perform inner-string cement jobs in a timely and efficient manner. These items include a set of drill pipe bowl and slips, a false rotary plate, and a centralizer to center the drill pipe inside the casing.

Davis Tag-In Equipment

Tag-In float equipment incorporates a receiver built into the float equipment (shoe or collar) that receives an adapter made up to the bottom of the inner string (usually drill pipe). The tapered concrete finish around the receiver guides the adapter into it. The Type B-122-C Tag-In Adapter is engaged to the receiver by straight-in movement. No rotation is required. Once engaged, a primary

and secondary seal are effected. Disengagement of the seal is achieved by picking the adapter up and out of the receiver. Once again, no rotation is required.

A popular choice of equipment for inner-string cementing larger diameter casings, from both onshore and offshore rigs, is the Davis Type 501-PVTS Float Shoe and the Type 700 T-PVTS Tag-In Float Collar. This equipment provides all the benefits that come with inner-string cementing through a float collar, including the option to run one or more shoe joints and the option to displace cement below the float collar without creating a "wet shoe."

For those preferring to inner-string cement through a shoe, Davis offers

the Type 501 DVT-PVTS Double-Valve, Down-Jet, Tag-In Float Shoe. This float shoe incorporates all the features and benefits built into the 501-PVTS Float Shoe and the Type 700 T Tag-In Float Collar.

Pack-Off Head Assemblies

Davis also has available the largest and most complete inventory of casing to drill pipe pack-off heads in the industry, if well hydraulics dictate the use of one when inner-string cementing. These heads are designed to seal the drill pipe/casing annulus and allow pressure to be applied to it. This pressure serves to offset pump pressure that creates collapse loading whenever inner-string cementing operations are conducted.

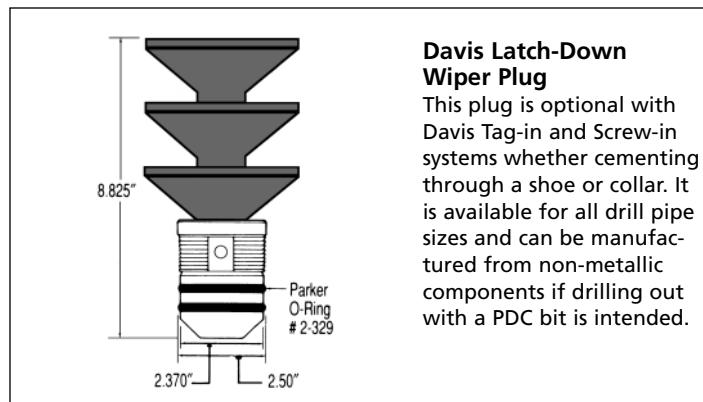
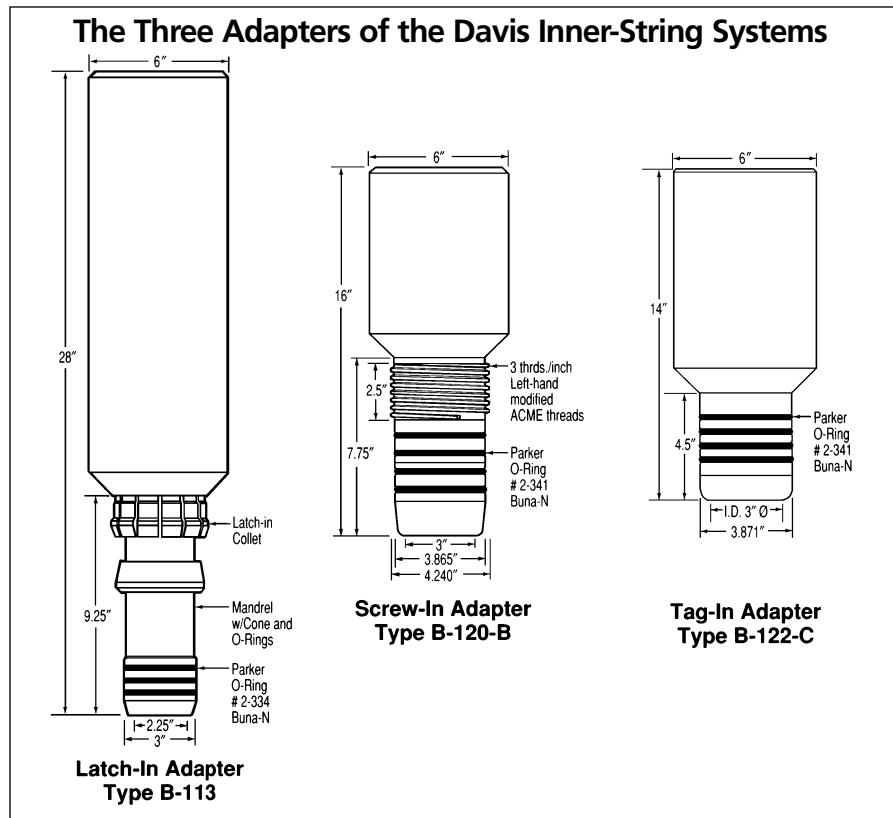

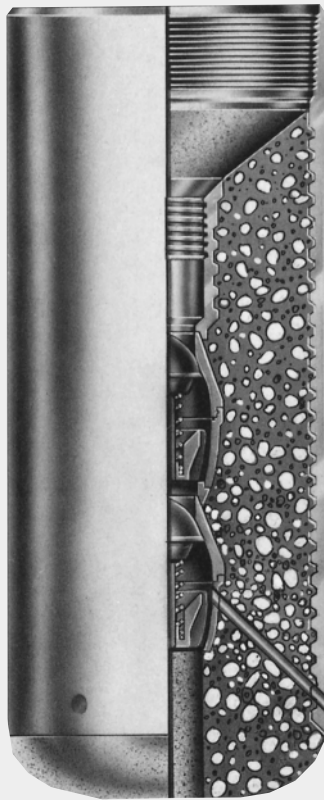

Type 501 DVS-PVTS

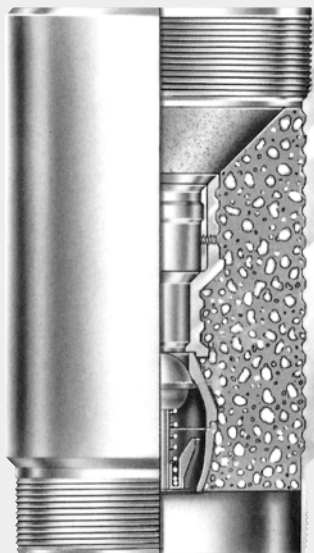

Type 700 L-PVTS

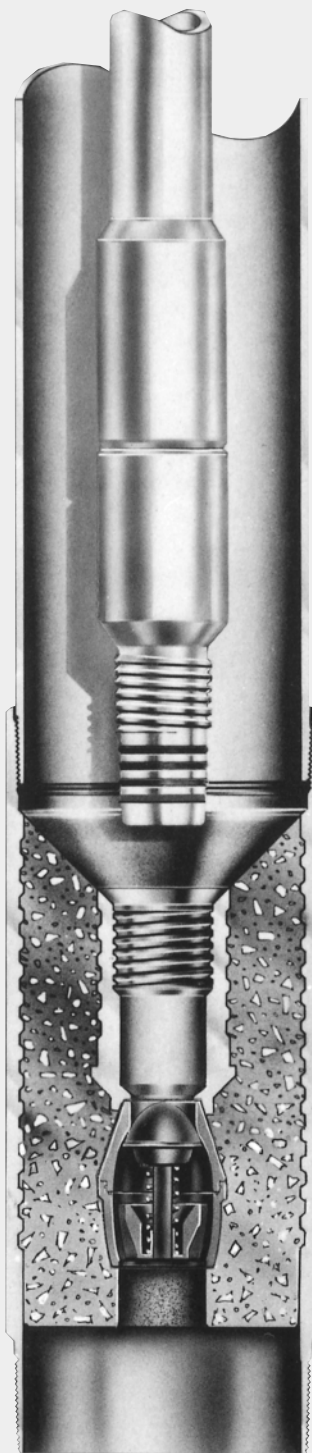

**Type 700 S-PVTS
Screw-In Assembly**

**Type 501 DVSLP-PVTS
Screw-In Shoe with
Hanger Assembly**

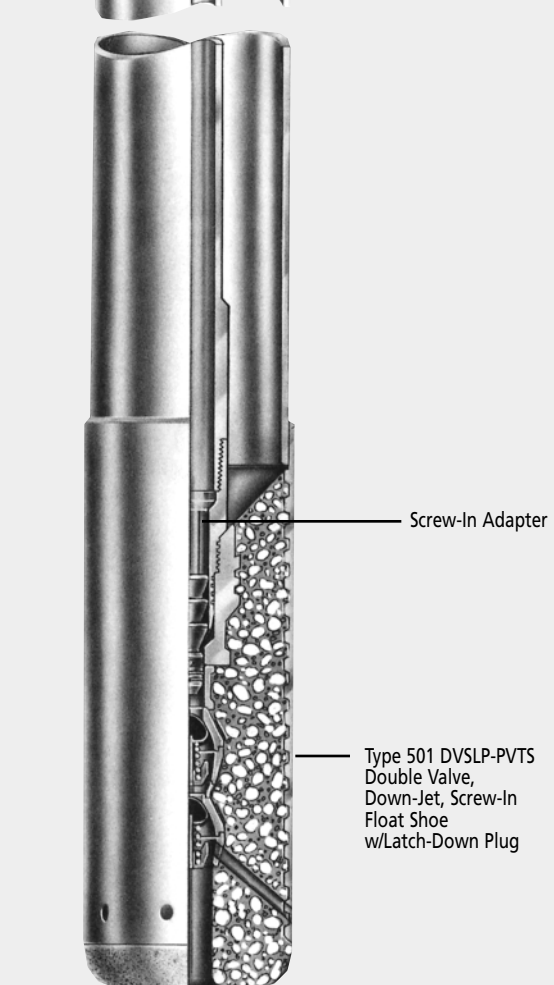
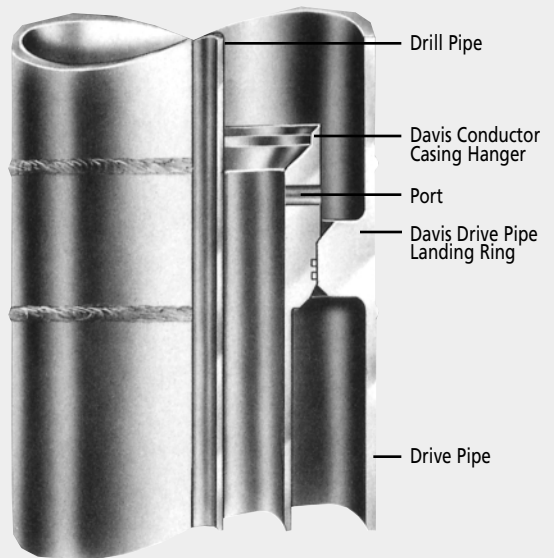

- Drill Pipe
- Davis Conductor Casing Hanger
- Port
- Davis Drive Pipe Landing Ring
- Drive Pipe
- Conductor Casing
- Screw-In Adapter
- Type 501 DVSLP-PVTS Double Valve, Down-Jet, Screw-In Float Shoe w/Latch-Down Plug

Davis Screw-In Equipment

Screw-In float equipment allows the adjoining of the inner-string to the casing at the float equipment. This adjoinment supports the load of the casing, allowing it to be lowered to bottom and inner-string cemented while being reciprocated. The equipment incorporates a strong receiver built into the float equipment (shoe or collar) that is capable of handling loads up to 300,000 pounds. Adjoinment between the Type B-120-B Adapter and the receiver is accomplished by applying left-hand rotation to the inner-string. No torque is required. Once the receiver and adapter are engaged, primary and secondary seals are effected between the two. Disengagement is attained by applying right-hand rotation to the inner-string while gradually picking it up.

Davis Screw-In equipment has created a whole new realm of economical uses with regard to its multiple applications. Among them:

1. Offshore, running and landing of the conductor casing string at either the mudline or the production deck. The string can be landed in tension by utilizing a Davis Drive Pipe Landing Ring and Davis Conductor Casing Hanger. (See graphic opposite page). This allows the operator to effectively seal off the conductor/drive pipe annulus. A second option is to allow the casing string to be landed on bottom or free standing in compression. Either application can save the operator rig time and related costs by eliminating the need for nipping-up well control equipment on the conductor casing string.

When conductor casing is suspended on a landing ring, at either the mudline or the production deck, the tapered top of the Davis casing hanger serves as an aid in protecting and guiding the bits to be used for the next hole section into the top of the liner. In addition to this, Davis can customize the top of the casing hanger to receive most brands of conventional mudline suspension or well-head housing equipment.

When conductor casing is set on bottom in compression, Davis offers the Type B-125 bit guide (see photo) that screws into the top of the liner. In addition, Davis manufactures a fluted casing hanger that is designed to land on this bit guide and suspend surface casing. Most brands of conventional, modular mudline suspen-

sion equipment can then be placed in the surface casing string for the purpose of landing and suspending ensuing casing strings.

2. Reciprocating full strings of casing while inner-string cementing. This application has proven extremely effective on geothermal wells where the absence of cement voids in the annulus is exceptionally critical if eventual casing collapse is to be avoided.

3. Setting a large-diameter liner to eliminate the cost of an expensive, conventional liner hanger, and realizing all the benefits inherent in inner-string cementing.



Type B-125 Bit Guide

As with all Davis inner-string equipment, the Screw-In style is available in several models including the Type 700 S-PVTS for those who prefer cementing through a float collar, and the Type 501 DVS-PVTS for those who prefer cementing through a float shoe.

Davis Latch-In Equipment

Davis also offers Latch-In equipment for inner-string cementing. It acts similar to Tag-In equipment with the additional feature of positively locking the adapter into the receiver. The Type B-113 Adapter is engaged to the receiver by straight-in movement. No rotation is required. Disengagement is accomplished by rotating the drill pipe one turn to the right and picking up on it. This action "un-jays" the collet that locks the adapter in place and allows it to compress and release from the receiver.

The adapter can also be released without damaging it by pulling approximately 40,000 pounds over the inner-string weight. This action

results in a safety sleeve being sheared out of the receiver. This back-up release feature should only be used if necessary.

Davis Latch-In equipment can be used when cementing from floating drilling vessels. It can also be used if unusually high pump rates are anticipated during cementing operations. The Latch-In mechanism will act to anchor the inner-string to the casing, eliminating the possibility of hydraulically pumping or "lifting" it out.

The Latch-In style of inner-string equipment is available in several models including the Type 700 L-PVTS Float Collar. This model provides the operator with all the benefits that come with inner-string cementing through a float collar, including the option to choose several shoe joints and the option to overdisplace cement below the float collar without creating a "wet shoe."

Davis Special Inner-String Cement Equipment

Davis has available, in either a shoe or collar, open-ended equipment that can be used to conduct inner-string cementing operations. The design of this equipment makes its use advantageous particularly when large-diameter/thin-walled casings of the type commonly run in storage wells are being cemented. The equipment incorporates two receivers, one to receive the standard Tag-In adapter and one to receive a special latch-down wiper plug that follows cement.

A popular choice for this application is the Davis Type 601 TLP Down-Jet, Tag-In Guide Shoe with Latch-Down Plug receptacle. Its open-ended feature allows casing to self-fill as it is run in the well. This eliminates the time that would normally be required to manually fill the casing. Once casing is on bottom, the inner-string is run and seal engagement occurs by use of the standard Tag-In adapter. A Davis Pack-Off Head Assembly is often rigged up at this point. At the conclusion of cement displacement, the special latch-down wiper plug is landed and locked into the shoe. Once latched, this plug provides the back-pressure check that is necessary to retain cement in the desired position.

Davis Extended Reach Equipment

Davis Flotation Collar*

The patented Davis Flotation Collar (DFC) is designed for use in running casing in substantially horizontal wellbores. Incorporated into the casing string, the device serves as a temporary barrier inside the casing. In so doing, it allows the portion of the string below it to be filled with air (no fluid) and the portion above it to be filled with drilling fluid.

Floating the bottom portion of the casing reduces the drag against the wellbore, while filling the upper portion with drilling fluid adds weight to the casing string to push it into the hole. This feature facilitates running casing in highly deviated wells and, in many cases, permits successful casing runs that would otherwise be extremely difficult if not impossible.

Once the opening sleeve is activat-

ed by casing pressure, allowing the drilling fluid to displace the air in the lower section of the casing string, normal cementing operations can begin immediately. Additional pressure on the bottom cementing plug releases the DFC assembly so that it can be pumped down to the float collar. The top cementing plug displaces the cement and lands and seals on the bottom cementing plug/DFC assembly.

Unlike earlier devices that must be set inside the casing and then retrieved after landing the casing (requiring one round trip of the drill pipe and spacing the top of the last casing joint at the rotary table), the Davis Flotation Collar is installed in the same manner as a float collar.

Applying pressure to the inside of the casing string is all that is required

to release the trapped air at the bottom of the casing string. This pressure is adjustable at time of manufacture to accommodate different pressure requirements.

The Davis Flotation Collar is self-contained and requires no other running, setting or retrieving tools. The inner sleeves of the device provide a good seal for the cementing plug against the float collar, and they are easily drilled out with either PDC or conventional rock bits when drilling the float equipment.

*Davis-Lynch does not warrant that use of the Davis Flotation Collar in a Selective Flotation System is free from infringement of any patented methods. Use of the Davis Flotation Collar in such a system may, for example, require permission from Unocal under U.S. Patent 4,986,361.

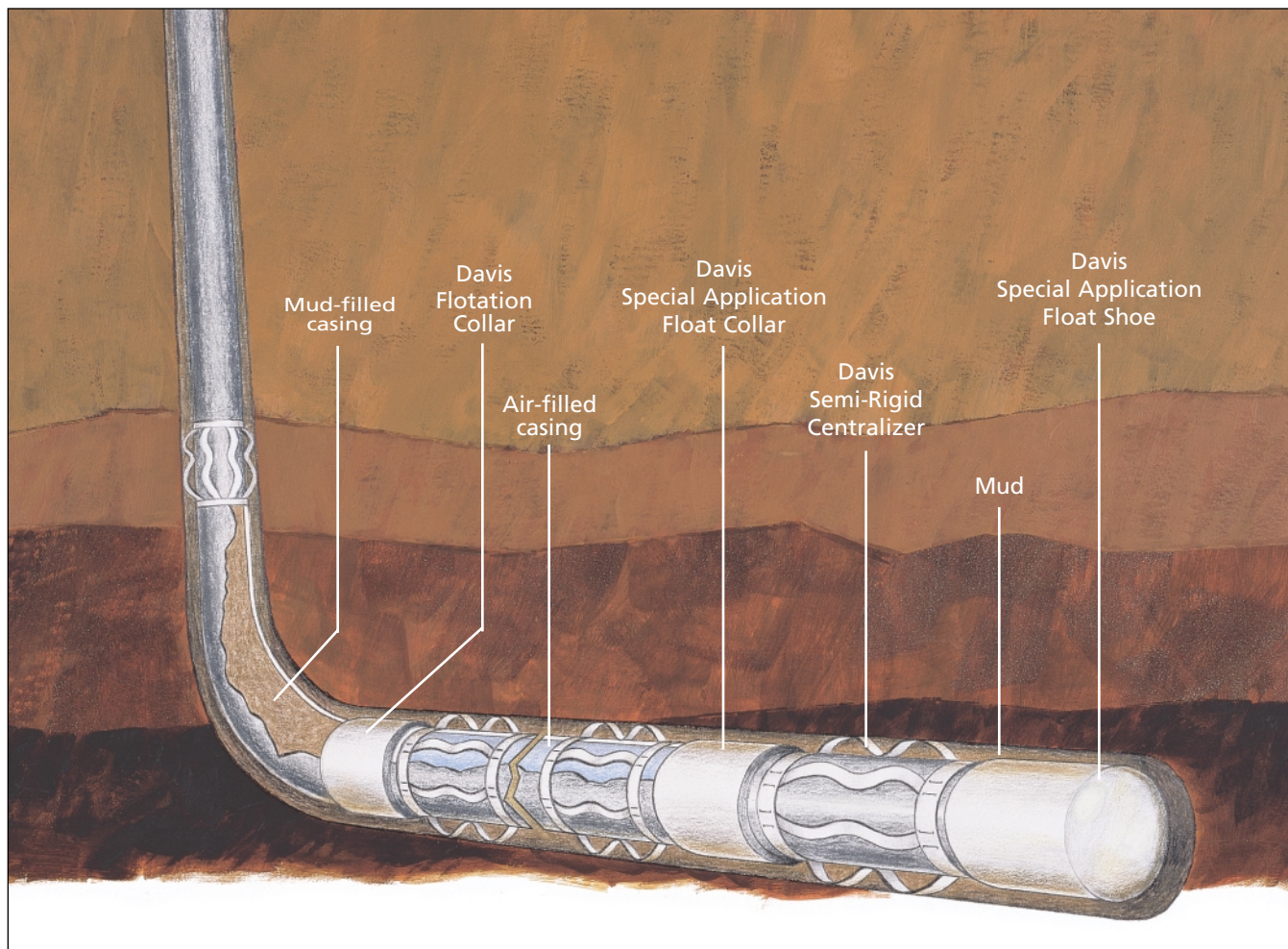

Davis Flotation Equipment Package

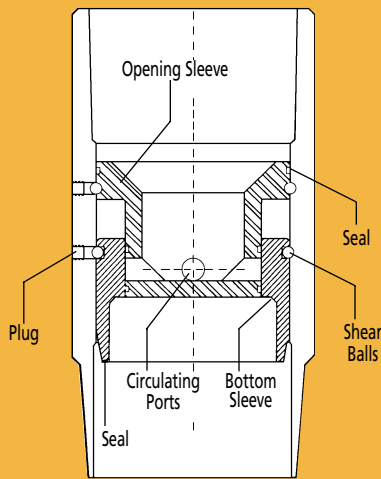

1.

Davis Flotation Collar (DFC)
 Bottom portion of casing is run dry (not filled with fluid), with DFC installed at desired depth. Casing above the DFC is filled with drilling fluid as casing run continues to desired depth.

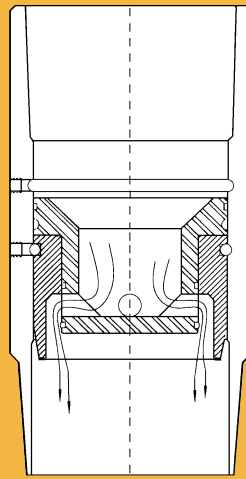

2.

Davis Flotation Collar (DFC)
 Casing pressure is increased until the opening sleeve shifts down to permit fluid and air to swap. After a fluid stabilization period, the casing is filled with drilling fluid.

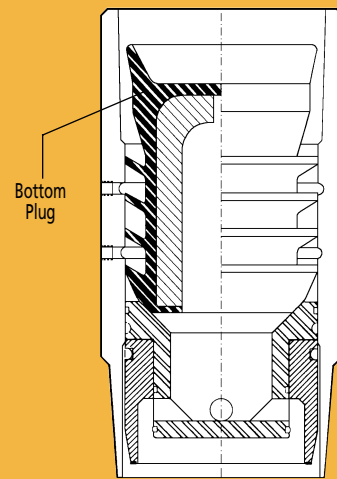

3.

Davis Flotation Collar (DFC)
 Bottom cementing plug is launched ahead of cement. After landing on the bottom sleeve, it pushes both DFC sleeves ahead of the cement to the float collar below.

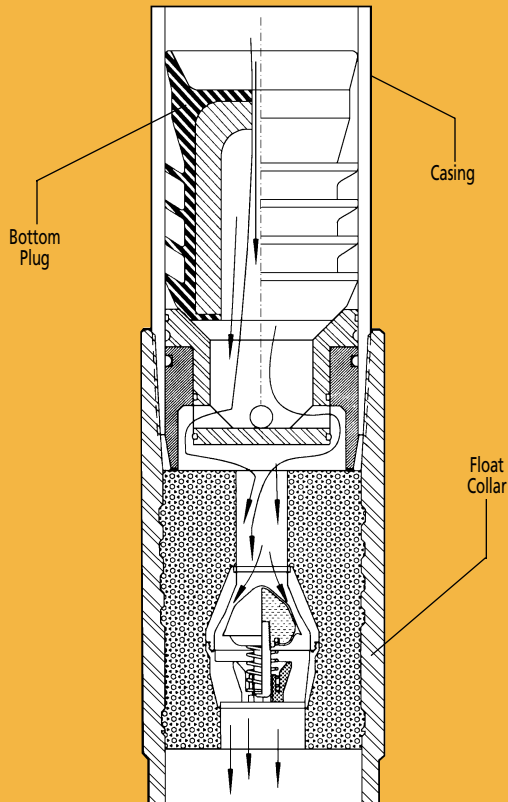

4.

Davis Flotation Collar (DFC)
 Bottom cementing plug and sleeves land and seal on the float collar. Bottom cementing plug ruptures, and cement is pumped through and out of the float equipment.

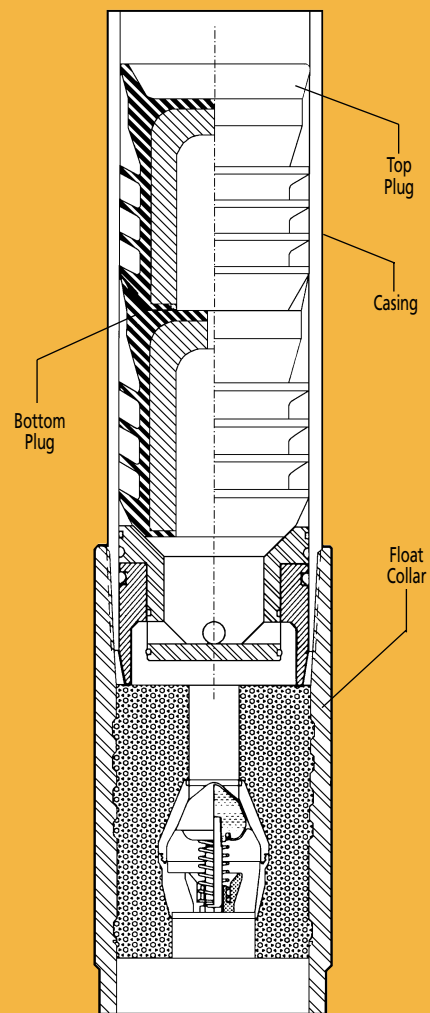

5.

Davis Flotation Collar (DFC)
 Top cementing plug is displaced and seals on bottom cementing plug/DFC assembly at the float collar.

Davis Cementing Enhancement Devices

Davis Non-Welded Centralizer*

Davis offers a full line of patented, non-weld centralizers. The centralizers feature a unique interlocking adjoinment between the end collar and bow spring, which makes for a strong singular unit. Davis Type "NW" centralizers are designed to exceed the performance requirements of API Specification 10D for both starting and restoring forces. (See data table this page)

Other design features of the Type "NW" centralizer include:

- Bow springs made of an alloy steel which are heat treated and tempered to a hardness to ensure proper and consistent spring characteristics.
- End collar hinges that are folded to the inside. This acts to minimize the collar stretch that tends to occur when centralizers encounter



tapers common to some pipe connections.

- A reinforcing rib stamped into the end collar. This acts to strengthen it and ensure maintenance of its round configuration during transport.
- Several different spring bow heights that are available to accommodate most any casing-to-hole configuration.
- Centralizers with built-in stop devices as well as those for unusual sizes available on request.

Davis Close-Tolerance Bow Spring Centralizer

In applications for running casing in close tolerances or slim holes, Davis offers a special type bow spring centralizer for these requirements. To provide optimum performance in close-tolerance holes, these centralizers feature low starting forces and high restoring forces. Centralizers consist of a solid type end collar for slipping over the pin end of casing joint. Some features/benefits include:

- Designed to meet or exceed API Specification 10D for starting and restoring forces.

- Available with set screws incorporated for integral stop, or can be run between stop devices for applications when casing is to be rotated.
- Typical applications include:
5-inch casing inside 6-inch hole,
7 5/8-inch casing inside 8 1/2-inch hole, and 9 5/8 inch casing inside 10 5/8-inch hole. Other sizes are available upon request.



Davis Non-Welded Semi-Rigid Centralizer (SRC)

This Davis product features uniquely profiled bows that simultaneously provide the operator with those features found desirable in both spring bow and rigid centralizers. The result is a centralizer that far exceeds the performance standards set forth in API Specification 10D.

Davis "NW" Type Centralizer Dimension and Performance Data

Casing Size (In Inches)	Hole Size (In Inches)	Product Number	Bow O.D. (In Inches)	Starting Force (In Lbs)		Restoring Force (In Lbs)	
				API	Davis	API	Davis
4-1/2	6	0450-NW2C	7-1/8	464	361	464	3000+
4-1/2	6-1/4	0450-NW2C	7-1/8	464	251	464	1140
4-1/2	6-1/2	0450-NW3C	7-5/8	464	355	464	2070
4-1/2	7-7/8	0450-NW4C	9-1/8	464	264	464	1040
5	6-1/4	0500-NW1C	7-1/8	520	175	520	650
5	6-1/2	0500-NW2C	7-5/8	520	273	520	3000+
5	7-7/8	0500-NW4C	8-1/8	520	190	520	1020
5	8-1/2	0500-NW4C	9-5/8	520	360	520	1650
5-1/2	7-7/8	0550-NW3C	8-5/8	620	240	620	650
5-1/2	8-1/2	0550-NW4C	10-1/8	620	520	620	1210
5-1/2	8-3/4	0550-NW4C	10-1/8	620	227	620	1310
5-1/2	9-7/8	0550-NW5C	11-1/8	620	280	620	1180
5-1/2	12-1/4	0550-NW6C	13-5/8	620	240	620	680
7	8-1/2	0700-NW2C	9-5/8	1040	720	1040	3000+
7	8-3/4	0700-NW3C	10-1/8	1040	795	1040	3000+
7	9-7/8	0700-NW4C	11-5/8	1040	720	1040	1910
7-5/8	9-7/8	0758-NW3C	10-3/4	1056	550	1056	1467
8-5/8	11	0858-NW3C	11-3/4	1440	400	1440	1470
8-5/8	12-1/4	0858-NW5C	14-1/4	1440	1120	1440	1850
9-5/8	12-1/4	0958-NW8C	14-3/4	1600	1389	1600	2175
10-3/4	12-1/4	1034-NW2C	13-3/8	2040	511	1020	2185
10-3/4	13-1/2	1034-NW4C	15-3/8	2040	645	1020	1385
10-3/4	14-3/4	1034-NW5C	16-3/8	2040	660	1020	1290
11-3/4	14-3/4	1134-NW4C	16-3/8	2160	624	1080	1411
11-3/4	15-1/2	1134-NW5C	17-3/8	2160	940	1080	1530
13-3/8	17-1/2	1338-NW5C	19	2400	830	1220	2330
16	20	1600-NW5C	21-5/8	2600	844	1300	1570
16	22	1600-NW6C	24-1/8	2600	1161	1300	2530
18-5/8	22	1858-NW5C	23-1/4	3500	2010	1750	3000+
18-5/8	24	1858-NW6C	26-3/4	3500	740	1750	1850
20	24	2000-NW5C	25-5/8	3760	1360	1880	1930
20	26	2000-NW6C	28-1/8	3760	1220	1880	2200

*U.S. Patent No. 4,909,322

As with the standard Davis Non-Welded Centralizer, the bows of the SRC are manufactured from alloy steel which is heat treated and tempered. During assembly they are adjoined to the end collars by the Davis patented interlocking method.

The design of the SRC's bows produces centralizers that have starting forces far below API maximums along with very low drag forces. The spring characteristic of the bows allows the SRC to compress in order to get through tight spots and severe doglegs that may be present downhole.

While the manufacture of the bows produces characteristics normally associated with standard spring bow centralizers, the double-crested profile of the SRC bow provides restoring forces that far exceed those standards set forth in API Specification 10D and which are normally associated with rigid



centralizers.

The SRC is ideally suited for running in horizontal and highly deviated wells where low running forces are a must. It can be run over casing connections or stop collars and, if requested, can be manufactured with a built-in stop device.

Davis Non-Welded Turbolizer

This is a centralizer with metal fins installed on the bows to help induce turbulence in the cement slurry during pumping operations. Like the spring bows, the fins are made of heat-treated alloy steel. This makes them flexible, which minimizes damage while moving downhole.

The Davis Turbolizer incorporates the same non-welded end collar-to-spring-bow interlocking adjoinment as the Davis centralizer. Turbolizers are available in the same sizes and bow heights as centralizers.

As with the Davis centralizer, turboliz-



ers can be manufactured with a built-in stop device. These items are available on special order.

Davis Cement Basket

A simple, economical type of annular packoff, the Davis Cement Basket is commonly used in situations where porous or weak formations require help in supporting a cement column. It is constructed of thin steel petals arranged in an overlapping pattern and reinforced by spring steel ribs. Its design allows cement to flow in an upward direction, yet helps to prevent it from falling downward.

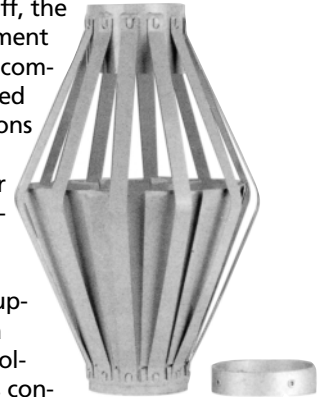

The basket is easily installed by sliding it over the pin end of a casing joint, prior to make-up of the joint. Travel range can be limited by a stop ring or by couplings. Available in sizes 4 1/2" and larger, the Davis Cement Basket is most effective when centralized and placed into a gauged section of the hole.

Davis "SR" Type Semi-Rigid Centralizer Dimension and Performance Data

Casing Size (In Inches)	Hole Size (In Inches)	Product Number	Bow O.D. (In Inches)	Starting Force (In Lbs)		Restoring Force (In Lbs)	
				API	Davis	API	Davis
4-1/2	6	0450-SR1C	6.06	464	171	464	4000+
4-1/2	6-1/4	0450-SR2C	6.38	464	<150	464	4000+
4-1/2	6-1/2	0450-SR3C	6.63	464	<150	464	3180
4-1/2	7-7/8	0450-SR7C	7.88	464	<150	464	3000
*5	6-1/2	0500-SR1C	6.56	520	<150	520	4000+
5	7-7/8	0500-SR6C	8.00	520	<150	520	3585
5	8-1/2	0500-SR8C	8.68	520	<150	520	4000+
5-1/2	7-7/8	0550-SR4C	7.88	620	<150	620	1720
5-1/2	8-1/2	0550-SR6C	8.50	620	<150	620	2910
5-1/2	8-3/4	0550-SR7C	8.88	620	<150	620	2540
5-1/2	9-7/8	0550-SR9C	9.68	620	<150	620	4000+
*7	8-1/2	0700-SR1C	8.63	1040	<150	1040	4000+
7	8-3/4	0700-SR2C	8.88	1040	783	1040	4000+
7	9-7/8	0700-SR6C	10.00	1040	<150	1040	4000+
7-5/8	9-7/8	0758-SR4C	10.00	1056	<150	1056	4000+
*8-5/8	11	0858-SR5C	11.00	1440	276	1440	4000+
8-5/8	12-1/4	0858-SR8C	12.31	1440	<150	1440	4000+
9-5/8	12-1/4	0958-SR5C	12.38	1600	683	1600	4000+
**10-3/4	12-1/4	1034-SR1C	12.38	2040	<150	1020	4000+
10-3/4	13-1/2	1034-SR5C	13.50	2040	<150	1020	4000+
10-3/4	14-3/4	1034-SR9C	15.00	2040	777	1020	4000+
11-3/4	14-3/4	1134-SR6C	14.81	2160	180	1080	4000+
11-3/4	15-1/2	1134-SR8C	15.50	2160	180	1080	4000+
13-3/8	17-1/2	1338-SR9C	17.63	2400	410	1220	4000+
16	20	1600-SR9C	20.25	2600	745	1300	4000+
18-5/8	22	1858-SR7C	22.06	3500	<150	1750	4000+
20	24	2000-SR9C	24.25	3760	605	1880	4000+
20	26	2000-SR10C	26.13	3760	757	1880	4000+

*Starting force derived from testing over stop collars.

**Starting force derived from testing over stop collars, recommended running only over a stop device.

Davis Non-Welded Rigid Centralizer

This Davis product features the patented adjoinment between end collar and spring bow first introduced in the Davis non-welded bow centralizer, along with all the features that operators demand in a rigid centralizer. These include the reduction in drag associated with running pipe in deviated and horizontal wells, the ability to provide optimum concentricity during casing cementing operations, and the ability to function equally well in either open or cased hole.

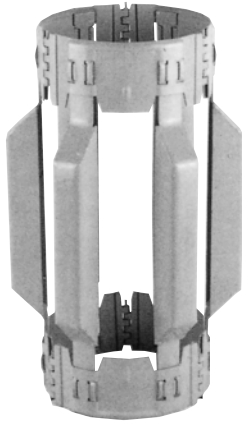

These centralizers are offered in a wide assortment of bow sizes to accommodate most casing-to-hole configurations.

Davis Stop Collars

Davis offers two designs of stop collars: a friction-grip type and a set-screw type. The friction grip type is hinged and incorporates a nut/bolt assembly which, when tightened,

draws the stop collar into a friction grip around the circumference of the pipe. It is manufactured from steel that meets ASTM A 569 specifications.

The set-screw type is a one-piece

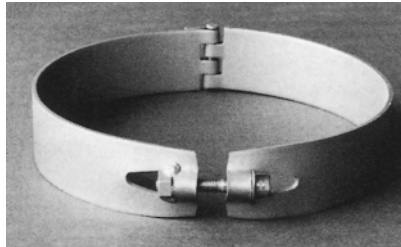

Stop Collar

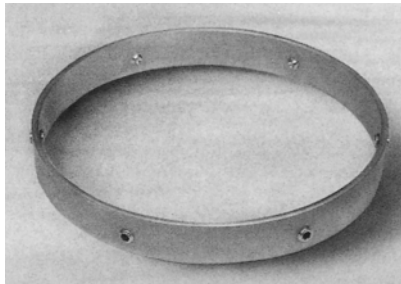

Davis also offers a premium one-piece stop-collar, with set screws for superior holding capability.

model that slips on the pipe and is held in place by tightening set screws against the casing. It is manufactured from steel that meets AISI M 1020 specifications. This design offers superior holding capability and is especially applicable in close tolerance situations.

Davis stop collars are stocked in all popular sizes ranging from 4 1/2" to 20". Unusual sizes are available on request.

Davis Spherical Stand-Off Device*

A new product that Davis is introducing is a spherical shaped stand-off device. This device is designed to promote positive stand-off, and significantly reduce the drag forces that are normally associated with other positive stand-off devices.

Features/benefits include:

- Spherical curvature of the blades in the vertical direction significantly reduces drag, prevents the blades from having "plowing effect," and reduces build up of cuttings around stand-off device.
- Spherical curvature of the blades around the circumference prevents edge of blades from embedding into formation for applications when casing is rotated.
- Blade shape and spacing of blades allows for optimum flow area around the blades of the device.
- Aluminum material prevents damage to the OD of the casing or previous casing strings, and reduces friction.
- Special high performance coating further prevents damage to casing strings and prevents galvanic corrosion. Coating also reduces tendency for cuttings to adhere to blades of device and reduces friction.
- Designed for both common and close tolerance applications.
- Utilized on applications for rota-

Davis "R" Type Rigid Centralizer Dimension Data

Casing Size (Inches)	Hole Size (Inches)	Product Number	Bow O.D. (Inches)
4 1/2	6	0450-RAC	5 3/4
4 1/2	6 1/4	0450-RAC	5 3/4
4 1/2	6 1/2	0450-RBC	6 1/8
4 1/2	7 7/8	0450-RFC	7 5/8
5	6 1/2	0500-RAC	6 1/4
5	7 7/8	0500-REC	7 3/4
5	8 1/2	0500-RFC	8 1/8
5 1/2	7 7/8	0550-RCC	7 5/8
5 1/2	8 1/2	0550-REC	8 1/4
5 1/2	8 3/4	0550-RFC	8 5/8
5 1/2	9 7/8	0550-RIC	9 5/8
7	8 1/2	0700-RAC	8 1/4
7	8 3/4	0700-RBC	8 5/8
7	9 7/8	0700-REC	9 3/4
7 5/8	9 7/8	0758-RCC	9 3/4
8 5/8	11	0858-RCC	10 3/4
8 5/8	12 1/4	0858-RGC	12 1/8
9 5/8	12 1/4	0958-RDC	12 1/8
10 3/4	12 1/4	1034-RAC	12
10 3/4	13 1/2	1034-RDC	13 1/4
10 3/4	14 3/4	1034-RHC	14 5/8
11 3/4	14 3/4	1134-REC	14 1/2
11 3/4	15 1/2	1134-RGC	15 1/4
13 3/8	17 1/2	1338-RHC	17 1/4
16	20	1600-RHC	19 7/8
16	22	1600-RJC	21 7/8
18 5/8	22	1858-REC	21 3/8
18 5/8	24	1858-RIC	22 3/4
20	24	2000-RHC	23 7/8
20	26	2000-RJC	25 7/8



Spherical Stand-Off Device

tion or reciprocation.

Contact your local Davis representative for more information.

*Patent pending

Davis Solid Body Flow Diverter

The Davis Solid Body Flow Diverter (SBFD) provides a rigid means of holding casing off the well bore. With blades placed at an angle, it creates a swirling motion that promotes more cleansing action for mud removal, more circulating area, and sufficient contact with the bore wall to provide centralization and prevent wall sticking.

SBFDs can be installed to remain stationary or move freely on the casing. Length of movement is determined by placement of stop devices or by couplings where applicable. In stationary positions, SBFDs will normally provide stand-off to allow circulation all around the casing string. When allowed to move freely, they serve as a series of bearings during reciprocation to reduce frictional drag.

Available in most casing/hole size configurations, the SBFDs have been successfully used to:

- Maintain centralization through positive stand-off.
- Enhance the effects of mud-wash pumped ahead of cement slurries.
- Aid in the removal of gelled mud from the annulus.
- Reduce torque required for casing



Solid Body Flow Diverter

rotation.

- Create a spiral turbulence around the casing to promote uniform cement bonding.

Davis Centralizer Application Analysis

Davis will, on request, run a computer-analyzed program that will recommend centralizer placement and project casing stand-off. All that is required are some simple pipe and well data, including casing size, casing weight, casing seat, hole size, mud weight and, when deviation is present, full survey data, including kick-off point, rate of build and final deviation. Since centralization is most critical through the cemented interval, anticipated top of cement is also

requested.

With these data, the computer can be set up to run the spacing/stand-off programs in two different modes. The first and most effective mode is "variable spacing." In this program, the relevant well data are entered and the computer calculates the number of centralizers to run, and how to space them, in order to meet whatever percent stand-off the customer desires for cement emplacement.

The second mode is "constant spacing." Using the same data required for the variable spacing mode, this program calculates what stand-off can be expected when the customer rather than the computer dictates the number of centralizers to be run, and at what spacing they will be run.

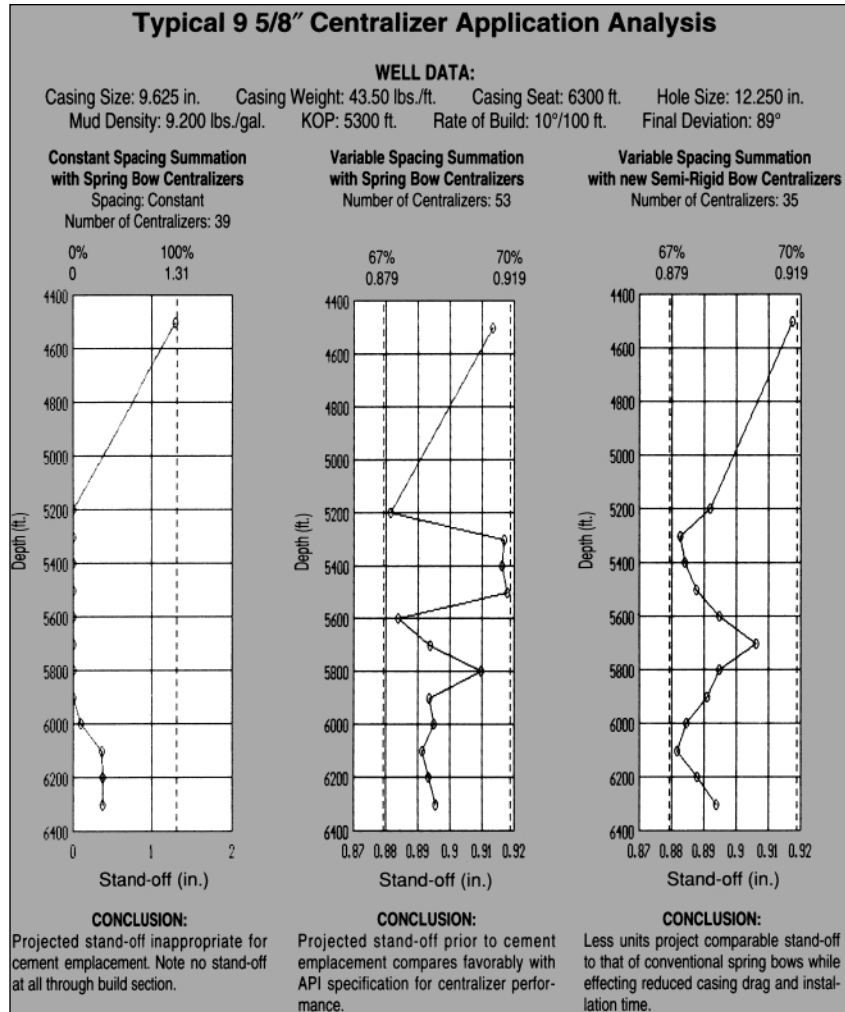

DAVIS STAGE CEMENTING COLLARS AND EQUIPMENT

For over 20 years, Davis stage cementing collars have been used by operators for their special applications. Now Davis offers three stage collar designs: a mechanically opened tool, a hydraulically opened tool, and a mechanically opened tool with a built-in inflatable packer.

Type 778 MC Mechanical Stage Cementing Collar

While now established as a field-proven tool, this tool continues to be the subject of research and development to find new materials for faster drill-out time, greater PDC bit drillability and better metal-to-metal sealing. Features of the 778 MC Stage Cementing Collar include:

- Tools can be made from material

grades up to 135,000 psi minimum yield, including material suitable for sour gas service.

- All parts are custom fitted and subjected to extensive quality control standards for maximum performance downhole.
- The connection that adjoins the stage collar body and the bottom sub effects a metal-to-metal seal and engages a back-up elastomer seal, the two of which are designed to provide gas-tight pressure integrity.
- No welds are used on any portion of the tool.
- The reduced length of the tool minimizes the effect of bending stresses.
- The seals providing internal and external pressure integrity are housed in the stage collar body and remain

stationary throughout operation, minimizing chances of their being damaged.

- The pressure-relief design prevents fluid trapping and compression between the opening device and the closing plug during the closing phase of the tool's operation.
- The closing sleeve is held in the closed position by an internal lock ring.
- Both the opening and closing sleeves lock against rotation for easy drill-out.
- A minimum amount of aluminum and rubber are the only materials encountered during drill-out.

Plug sets for four different cementing applications are available (pp. 20, 21).

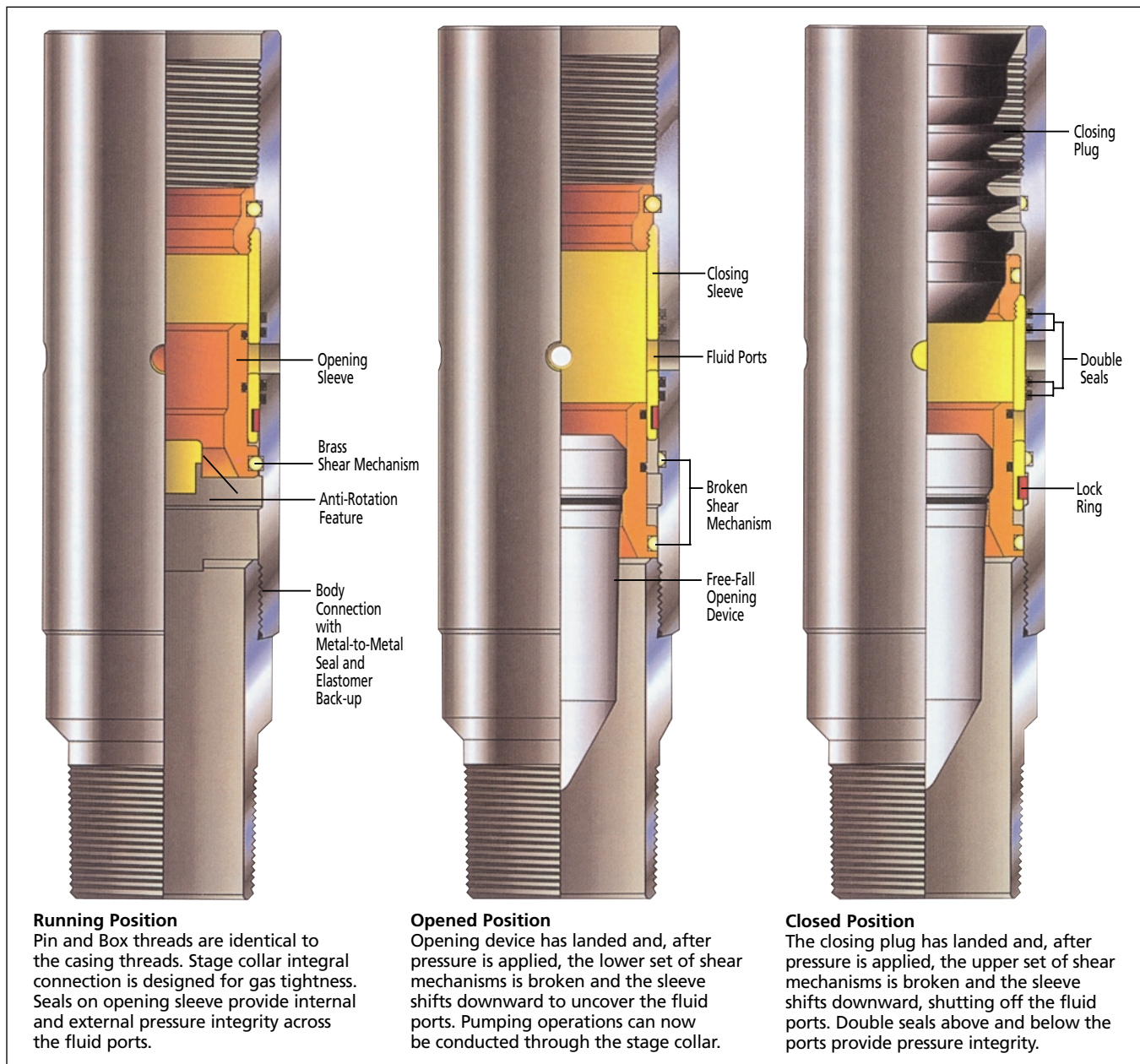

Type 777 HY Hydraulic-Opening Stage Cementing Collar

This stage collar features an opening sleeve with area differences on opposite ends that allows it to be manipulated hydraulically. The closing sleeve is identical to the one contained in the Davis Type 778 MC Mechanical Stage Cementing Collar. The development and introduction of this model was spurred on by the tremendous upswing in horizontal drilling activity that has occurred in recent years. The hydraulic-opening feature makes this tool's use very practical in horizontal wells.

The elimination of the need to use a mechanical opening device has several other merits. Casing runs in highly deviated wells can now be two-

stage cemented without having to use continuous displacement type plugs. In certain applications, liners run with drill pipe can be run in conjunction with one or several inflatable packers and used to isolate and selectively cement certain casing intervals. Slotted or pre-drilled liner can be run below a Davis inflatable packer/hydraulic stage collar assembly, allowing cement to be pumped above the packer and isolated from highly sensitive producing zones.

Along with all the features inherent in the 778 MC Stage Cementing Collar, the Type 777 HY offers:

- Effective differential area on the opening sleeve that generates a high

opening force while requiring only optimal pressure to do so.

- The ability to open immediately upon the completion of first-stage cement displacement.
- Opening pressure values that can be adjusted at the time of assembly to assure that all inflatable packers or other hydraulic tools present in the casing string will be triggered at the correct juncture. (See Specification Table on page 22)

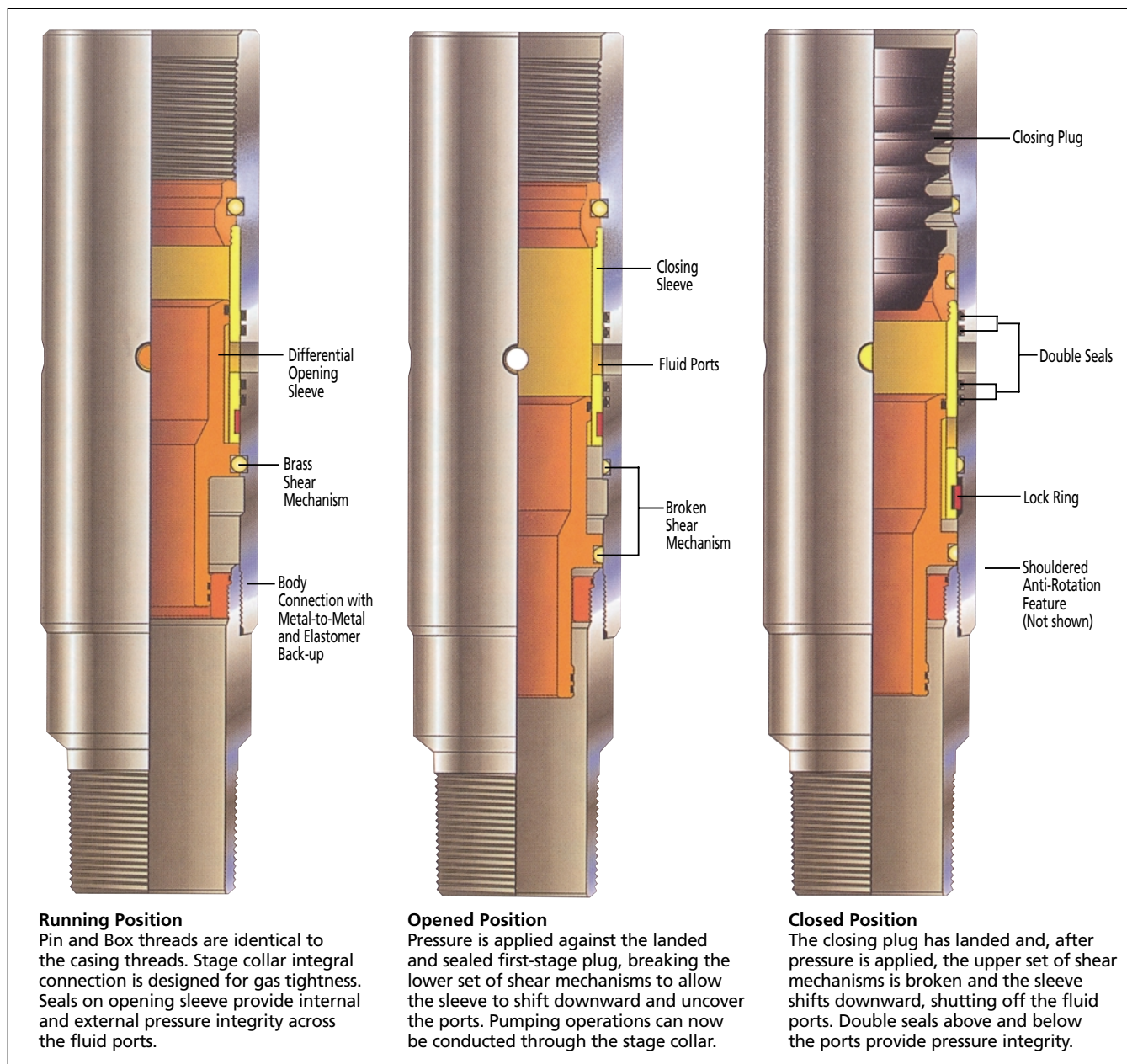

Stage Cementing Plug Systems

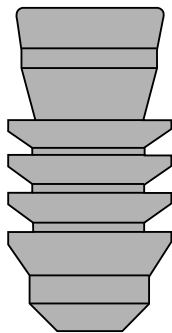

Closing Plug

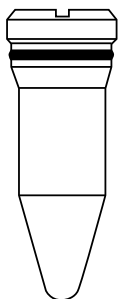

Free-Fall Opening Device

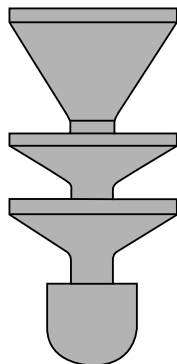

First Stage Sealing Plug

Two-Stage Cementing with the Type 778 MC using a First-Stage Sealing Plug, Free-Fall Opening Device, and Closing Plug

1. A Davis float shoe and float collar along with the Type 778 MC Stage Collar, are installed in the casing string and the casing is run to bottom.
2. Circulation is established and first-stage cement is mixed and pumped.
3. The first-stage sealing plug is launched and cement is displaced. At the conclusion of displacement, the first-stage sealing plug lands and effects a seal against the Davis float collar. No baffle is required.
4. The free-fall opening device is dropped and allowed to gravitate to position. Pressure is applied to the casing and the stage collar is opened.
5. Circulation is established and second-stage cement is mixed and pumped.
6. The closing plug is launched and cement is displaced. At the conclusion of displacement, the closing plug lands and effects a seal in the stage collar. Pressure is applied to the casing and the stage collar is closed.

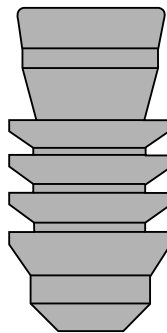

Closing Plug

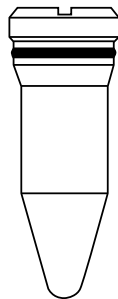

Free-Fall Opening Device

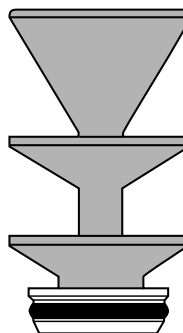

First Stage Shut-Off Plug

Shut-Off Baffle
Painted Yellow

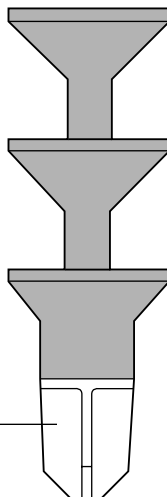

By-Pass Plug

Painted Yellow

Two-Stage Cementing with the Type 778 MC using a By-Pass Plug, Shut-Off Plug and Baffle, Free-Fall Opening Device, and Closing Plug*

1. A Davis float shoe and float collar along with the Type 778 MC Stage Collar, are installed in the casing string and the casing is run to bottom. The yellow shut-off baffle is installed in the casing string at least (1) one joint above the Davis float collar. If API threads are run (8RD or Buttress) the baffle can be installed in the "J" section of a coupling. If premium threads are run, a separate baffle collar must be run.
2. After the hole is conditioned, the by-pass plug with the yellow nose piece is launched ahead of first-stage cement. This plug will pass through the shut-off baffle and land on any Davis manual- or self-fill float collar. Once landed, approximately 50 psi will invert the wipers on the by-pass plug and allow cement to pass.
3. After cement is mixed and pumped, the shut-off plug is launched and cement is displaced. At the conclusion of displacement, the shut-off plug lands and effects a seal in the shut-off baffle.
4. The opening of the stage collar and the ensuing second-stage cementing and closing of the stage collar are carried out identically to that described for two-stage cementing with first-stage sealing plug.

*NOTE: When using the Type 777 HY Hydraulic-Opening Stage Collar, the standard plug system is a first-stage shut-off baffle, a first-stage shut-off plug, a contingent opening device, and a closing plug. A first-stage latch-in plug with a special Davis float collar is available on request.

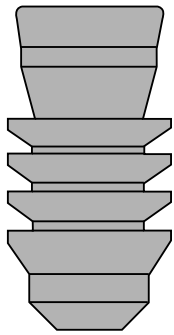

Closing Plug

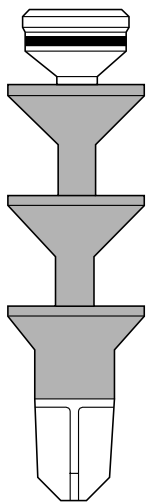

Pump Down Opening Plug

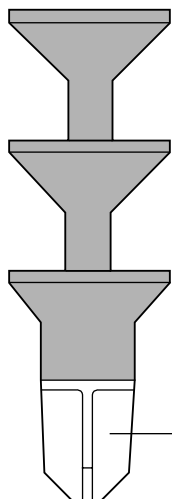

By-Pass Plug

Continuous Two-Stage Cementing with the Type 778 MC using a By-Pass Plug, Pump-Down Opening Plug, and Closing Plug.

In this application, the by-pass plug follows first-stage cement and it is advisable to run a minimum of two joints between the float shoe and float collar.

1. After first-stage cement is mixed and pumped, release the by-pass plug and begin displacing. Once the calculated volume of displacement fluid between the stage collar and the float collar has been pumped, less a pre-determined amount acting as a safety buffer, release the pump-down opening plug.

2. As the pump-down opening plug approaches the stage-collar, slow the pump rate to 1-2 bbls./min. Once the plug has landed in the opening seat (indicated by a pressure increase), apply pressure to the casing to open the stage collar.

3. Once the stage collar is open, second-stage circulating, cementing, and closing operations may be carried out as previously described.

Painted Yellow

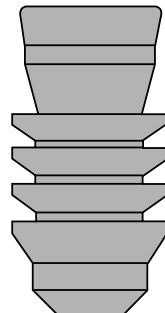

Closing Plug

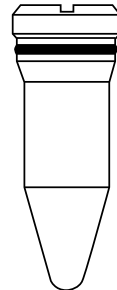

Free-Fall Opening Device

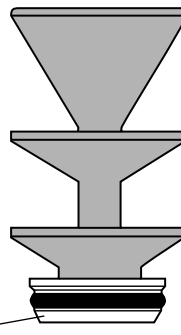

Closing Plug

Red Nose Piece

Painted Red

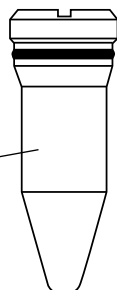

Free-Fall Opening Device

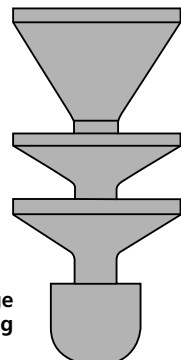

First Stage Sealing Plug

THIRD STAGE

SECOND STAGE

FIRST STAGE

Three-Stage Cementing with the Type 778 MC and the Type 778 MC-3S Stage Cementing Collars

The Type 778 MC-3S stage collar is identified by its red markings and is always run as the lower of the two tools. Its free-fall opening device and closing plug are also identified by their red markings. The upper stage collar is always the Type 778 MC and the free-fall opening device and closing plug for it are standard.

The first-stage sealing plug is standard and will pass through both stage collars and land and seal on any manual- or self-fill Davis float collar.

First-, second-, and third-stage cementing and displacing operations, including opening and closing both tools, are carried out as previously described.

DAVIS STAGE CEMENTING COLLARS AND EQUIPMENT

Specification Tables

Davis Type 778 MC and Type 778 MC-3S (Three Stage)

Nominal Casing Size (In.)	Maximum Diameter	Wt. Range (Lbs.)	Drill-Out I.D. (Inches)	Overall Length (Inches)	Opening		Closing		Type 778 MC		Type 778MC3S	
					Pressure (PSI)	Force (Lbs.)	Pressure (PSI)	Force (Lbs.)	Opening Seat ID (Inches)	Closing Seat ID (Inches)	Opening Seat ID (Inches)	Closing Seat ID (Inches)
2 7/8	3.660	6.4-7.8	2.440	24.75	1000	4,676	1500	9,636	1.750	2.125		
3 1/2	4.380	7.7-10.2 12.7-14.1	2.930	24.75	1200	8,107	1500	15,481	1.750	2.125		
4 1/2	5.562	9.5-13.5	3.950	27.25	1200	21,000	1500	25,000	2.750	3.062	2.250	2.500
5	6.090	11.5-15.0	4.300	27.25	1200	26,000	1500	33,000	2.750	3.250	2.250	2.500
5 1/2	6.625	14.0-17.0 20.0-23.0	4.892 4.810	27.38	1200	32,000	1500	39,000	3.750	4.062	2.750	3.062
6 5/8	7.875	20.0-28.0	6.030	28.50	1200	45,000	1500	57,000	4.625	5.000	3.750	4.187
7	8.275	17.0-23.0 26.0-29.0 32.0-38.0	6.276 6.200 6.004	28.50	1200	49,000	1500	62,000	4.625	5.125	3.750	4.250
7 5/8	8.937	26.4-33.7	6.825	28.88	1200	59,000	1500	74,000	4.750	5.550	3.750	4.250
8 5/8	10.125	24.0-32.0	8.000	29.00	1000	71,000	1200	85,000	5.750	6.750	4.750	5.250
9 5/8	11.125	32.3-40.0 43.5-53.5	8.921 8.600	29.50	1000	78,000	1200	94,000	7.000	7.750	5.750	6.500
10 3/4	12.375	40.5-45.5	9.950	30.88	1000	100,000	1200	120,000	8.000	8.750	7.000	7.500
11 3/4	13.375	42.0-54.0	10.825	30.88	1000	114,000	1200	137,000	8.000	8.750	7.000	7.500
13 3/8	15.000	54.5-61.0 68.0-72.0	12.515 12.415	30.88	900	133,000	1000	148,000	10.500	11.250	8.000	9.750
16	18.000	65.0 75.0-84.0	15.125 14.880	32.38	500	90,000	700	126,000	13.125	14.000		
18 5/8	20.800	87.50	17.755	32.88	400	99,000	600	149,000	14.500	16.000		
20	22.000	94.0-133.0	18.730	32.88	400	110,000	600	165,000	16.000	17.500		
22	24.000	114.8-170.2	20.500	34.63	400	135,000	600	228,000	18.000	19.000		

Note: 4 1/2" thru 6 5/8" have 4-1" Ports. 7" thru 13 3/8" have 6-1 1/8" Ports. 16" thru 20" have 10-1 1/8" Ports. 22" has 12-1 1/8" Ports.

Davis Hydraulic-Opening Stage Cementing Collar Type 777 HY

Nominal Casing Size (Inches)	Maximum Diameter (Inches)	Weight Range (Lbs.)	Drill-Out I.D. (Inches)	Overall Length (Inches)	Opening*		Closing		Opening Seat I.D. (Inches)	Closing Seat I.D. (Inches)	Opening Pressure w/Free Fall Device (PSI)
					Pressure (PSI)	Force (Lbs.)	Pressure (PSI)	Force (Lbs.)			
3 1/2	4.380	7.7-10.2 12.7-14.1	2.930	24.75	2000	6,716	1500	15,481	1.375	2.125	1200
4 1/2	5.562	9.5-13.5	3.950	27.25	3000	14,000	1500	25,000	2.500	3.125	1100
5	6.090	11.5-15.0	4.300	27.25	3000	18,000	1500	33,000	2.625	3.250	1100
5 1/2	6.625	14.0-17.0 20.0-23.0	4.892 4.810	27.38	3000	23,000	1500	37,000	3.060	4.062	1200
7	8.275	17.0-23.0 26.0-29.0 32.0-38.0	6.276 6.200 6.004	28.50	2600	28,000	1500	57,000	4.250	5.125	1000
7 5/8	8.937	26.4-33.7	6.825	28.88	2600	41,000	1500	68,000	4.250	5.500	1000
8 5/8	10.125	24.0-32.0	8.000	29.00	2500	48,000	1500	84,000	5.375	6.750	1000
9 5/8	11.125	32.3-40.0 43.5-53.5	8.921 8.600	29.50	2400	50,000	1500	111,000	6.300	7.750	1000
10 3/4	12.375	40.5-45.5	9.950	30.88	2300	63,000	1500	130,000	7.000	8.750	1000
11 3/4	13.375	42.0-54.0	10.825	30.88	2300	94,000	1500	156,000	7.000	8.750	1000
13 3/8	15.000	54.5-61.0 68.0-72.0	12.515 12.415	30.88	2000	96,000	1200	161,000	8.000	11.250	900
16	18.000	65.0 75.0-84.0	15.125 14.880	32.62	1850	116,200	700	140,740	10.250	14.000	640
20	22.000	94.0-133.0	18.730	32.63	600	143,500	600	188,500	13.500	17.500	160

*Standard opening pressure. Other pressures available on special order.

Note: 4 1/2", 5" and 5 1/2" have 4-1" ports. 7" thru 13 3/8" have 6-1 1/8" ports. 16" thru 20" have 10-1 1/8" ports.

Type 778-100 Packer Stage Cementing Collar*

This widely accepted Davis product combines an inflatable packer and a stage cementing collar into a singular unit. The stage collar portion of this tool uses the same sleeve and mechanical systems as the field-proven Davis Type 778 Stage Cementing Collar.

The packer portion of this tool uses the same element design as the field-proven Davis Type 100 Integral Casing Packer. This element consists of an innertube housed and protected by continuous, mechanically end-anchored, spring-steel reinforcing strips that are leafed on top of each other. These strips are encased in an oil-resistant outer rubber. Expansion is obtained by injecting fluid into the innertube. This injection forces partial un-leafing of the steel strips which in turn stretches the outer rubber until it effects a full-length seal against the

bore it is run in, whether cased or open hole.

While the packer is expanding, the bottom end of the element is drawn up on a ratchet-type locking mechanism. This feature is intended to keep the element mechanically expanded so it can provide some form of support in the event of hydraulic failure.

Once inflation pressure is reached, simultaneous sealing of the fluid injection inlets and opening of the cementing ports occur. This action allows the immediate introduction of fluid to the annulus after the packer is set. The inflation of the packer also serves to center the tool in the wellbore, leading to uniform distribution of cement as it exits the casing.

Although the combination packer stage collar serves two purposes, it is only one tool. This means that it can be serviced by one person, which

eliminates the cost of the second person who would be required if a stage collar and inflatable packer were individually purchased from two separate companies.

The Davis Type 778-100 Packer Stage Cementing Collar has multiple applications. It can be used to:

- Keep the hydrostatic head of second-stage cement off first-stage cement.
- Keep the hydrostatic head of second-stage cement off pressure sensitive zones below it.
- Keep cement from falling around pre-drilled or slotted liners.
- Selectively place cement across widely separated zones of interest.
- Prevent gas migration that can ruin primary cement jobs and lead to annular gas problems at the surface and expensive squeeze work.

Davis Packer Stage Cementing Collar Type 778-100

Nominal Casing Size (In.)	Type Number 778-100	Weight Range (Lbs.)	Drill-Out I.D. (Inches)	Maximum Diameter (Inches)	Opening		Closing		Opening Seat I.D. (Inches)	Closing Seat I.D. (Inches)	Maximum Recommended Differential Pressure (PSI) Across Packer in Various Hole Sizes (In.)						
					Pressure (PSI)	Force (Lbs.)	Pressure (PSI)	Force (Lbs.)			1000	1500	2000	2500	3000	3500	4000
4 1/2	450-575	9.5-13.5	3.950	5 3/4	900	16,000	1500	26,000	2.750	3.125	10 3/4	10 1/4	9 3/4	9 1/4	8 3/4	8 1/4	7 3/4
5	500-638	11.5-15.0	4.300	6 3/8	900	20,000	1500	33,000	2.750	3.250	11 1/4	10 3/4	10 1/4	9 3/4	9 1/4	8 3/4	8 1/4
5 1/2	550-700	14.0-17.0 20.0-23.0	4.892 4.658	7	1500	39,000	1500	39,000	3.438	4.062	12	11 1/2	11	10 1/2	10	9 1/2	9
6 5/8	663-800	20.0-28.0	6.030	8	900	34,000	1500	57,000	4.250	5.000	13	12 1/2	12	11 1/2	11	10 1/2	10
7	700-825	23.0-26.0 29.0-35.0	6.276 6.200	8 1/4	1500	61,000	1500	62,000	4.625	5.125	13 1/4	12 3/4	12 1/4	11 3/4	11 1/4	10 3/4	10 1/4
7 5/8	763-900	26.4-33.7	6.825	9 1/16	900	44,000	1500	74,000	4.750	5.500	14	13 1/2	13	12 1/2	12	11 1/2	11
8 5/8	863-1025	24.0-32.0	7.980	10 1/4	900	58,000	1500	95,000	5.750	6.750	15 1/4	14 3/4	14 1/4	13 3/4	13 1/4	12 3/4	12 1/4
9 5/8	963-1125	32.3-40.0 43.5-53.5	8.921 8.600	11 1/4	900	70,000	1500	117,000	7.000	7.750	16 1/4	15 3/4	15 1/4	14 3/4	14 1/4	13 3/4	13 1/4
10 3/4	1075-1275	40.5-45.5 55.5-65.7	9.950 9.600	12 3/4	800	80,000	1200	120,000	8.000	8.750	17 3/4	17 1/4	16 3/4	16 1/4	15 3/4	15 1/4	14 3/4
13 3/8	1338-1575	54.5-61.0 68.0-72.0	12.515 12.415	15 3/4	600	89,000	1200	178,000	10.250	11.250	22 1/4	21 3/4	21 1/4	19 3/4	19 1/4	18 3/4	18 1/4

NOTE: Packer stage collars equipped with six cement ports. 1 1/4" diameter on sizes 7" and above, and 1" diameter on smaller sizes. Standard seal length of inflatable packer elements is 36 inches. For special sizes or varying seal lengths consult your nearest Davis representative. Total length of packer stage collar is approximately 120" depending on type threads used.

With simple changes to tool IDs and plug and tripping device ODs, all three Davis stage collar designs—the mechanical, the hydraulic and the mechanical with inflatable packer, are made readily available for three-stage applications. See tables for standard sizes. Contact your Davis representative for availability of sizes not shown.

*U.S. Patent No. 5,024,273

The Type 778-100 Packer Stage Cementing Collar

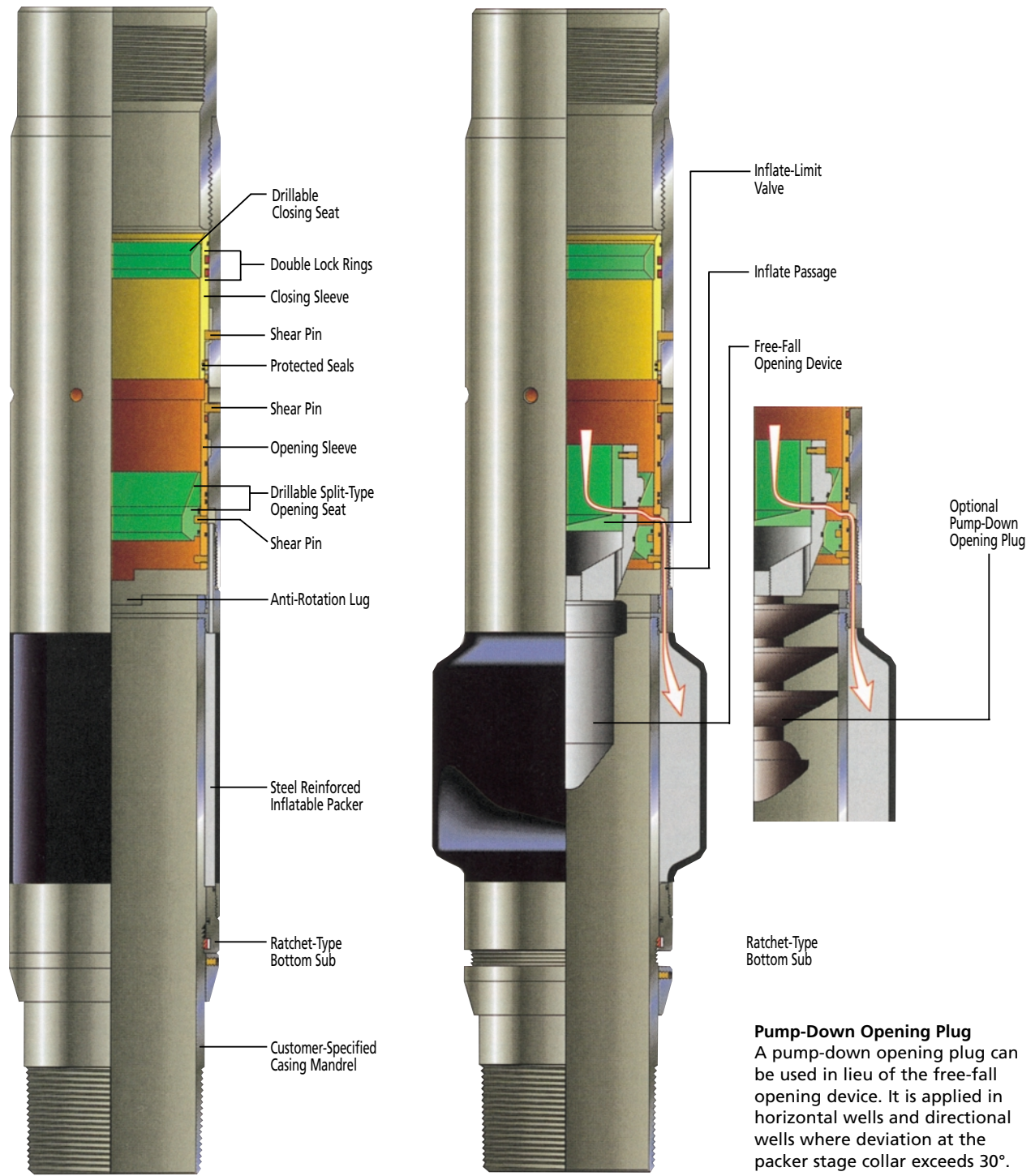

Running in Hole

Shows packer stage cementing collar in running position with opening and closing sleeves pinned in place. Lower section of split-type opening seat isolates inflate passage preventing premature inflation of the packer.

Inflating Element

The free-fall opening device enters split-type opening seat shearing the the pins in the lower section. This allows lower section to move down exposing the inflatable packer element to the fluid and pressure inside the casing. Fluid enters the packer element through the double-seal in the free-fall opening device and the split-type opening seat and inflation passage in the tool body.

Pump-Down Opening Plug

A pump-down opening plug can be used in lieu of the free-fall opening device. It is applied in horizontal wells and directional wells where deviation at the packer stage collar exceeds 30°.

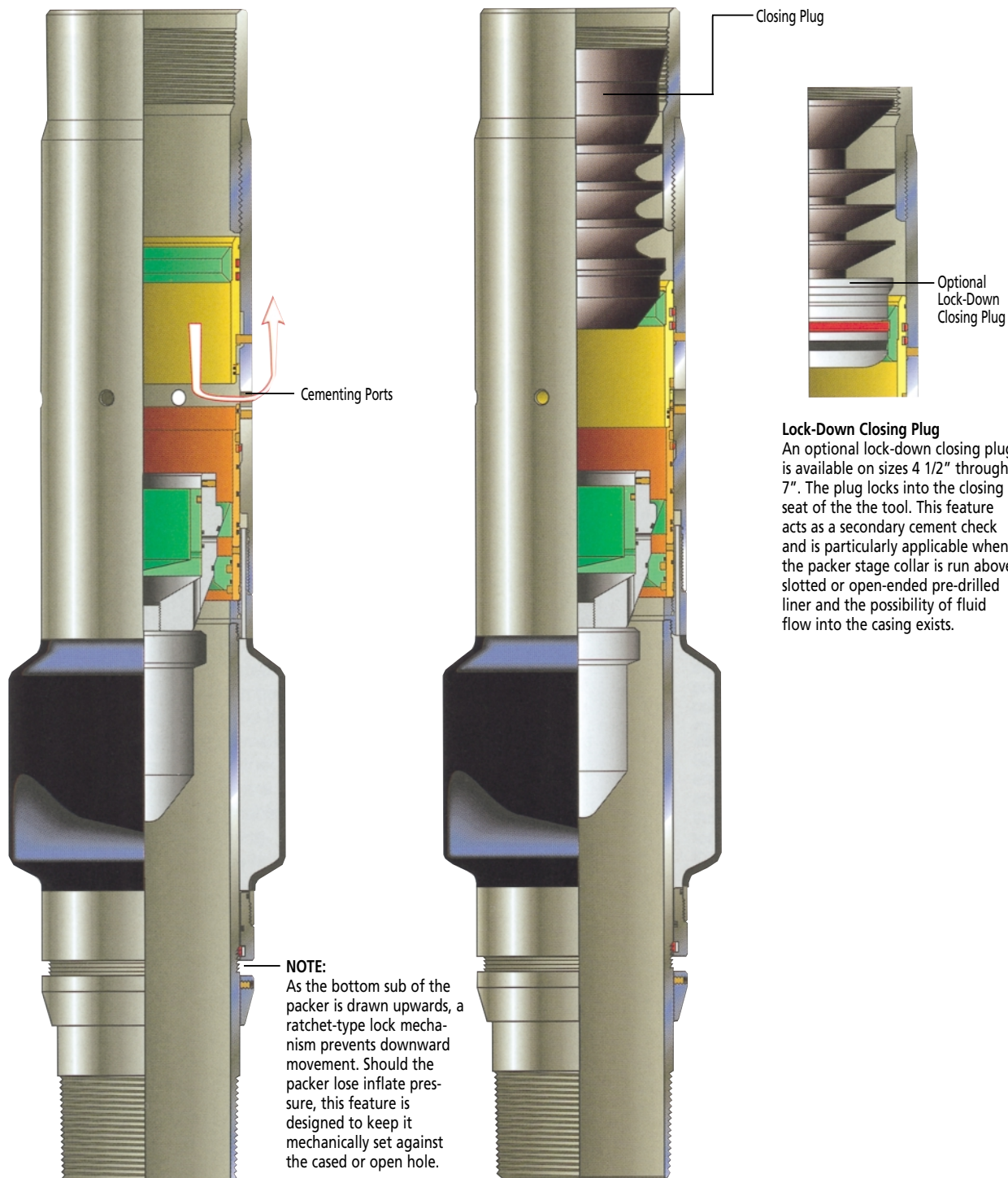

Lock-Down Closing Plug

An optional lock-down closing plug is available on sizes 4 1/2" through 7". The plug locks into the closing seat of the tool. This feature acts as a secondary cement check and is particularly applicable when the packer stage collar is run above slotted or open-ended pre-drilled liner and the possibility of fluid flow into the casing exists.

Opening Cement Ports

With the free-fall opening device in place, pressure applied to the casing shears the pins in the opening sleeve and moves it downward to the open and locked position. This movement seals off the inflate passage and permanently traps the correct inflate pressure in the packer. The inflate-limit valve in the free-fall opening device insures that the correct inflate pressure is achieved but never exceeded when opening tool.

Closing Cement Ports

Once cement has been displaced and the closing plug seats in the closing sleeve, additional pressure is applied to the casing. This pressure shears the pins and allows the closing sleeve to travel downward to its final closed and locked position. The pressure required to do this varies with the tool size and the type of job performed.

Davis Inflation Packers

The Davis line of inflatable packers features a weldless design that provides a strong and effective seal. They are available for virtually all drilling, completion and workover requirements, as well as for pipeline testing and repair and offshore platform installation.

Inflatagrip Longseal* Packers

These Davis Packers, available with 20- or optional 40-foot length seals, provide a positive seal against fluid or gas movement in the annulus of vertical, deviated or horizontal wells. They are recommended for use where naturally occurring fracture systems and high permeability streaks require a longer seal for more positive zone isolation. Mud- or cement- filled Inflatagrip Longseal Packers will conform to and seal in washed-out, elliptical or other irregularly shaped wellbores. They are of the limited steel rib reinforcing type in that the ribs do not extend completely from one end of the seal to the other. This feature allows the non-reinforced center portion of the packer to expand and seal in larger, irregularly shaped wellbores and still be retained at the ends by the overlapping steel Inflatagrip reinforcing ribs.

Features/Benefits of Types 202 and 402 Inflatagrip Longseal Packers:

- Patented Inflatagrip® end reinforcing metal ribs anchor against wall of well for positive end containment during and after inflation.

- Reinforcing metal ribs mechanically attached at each end of the element, along with the single durometer rubber element, assure a uniform inflation between the metal ribs to displace a maximum amount of mud from the seal area.
- Mechanical anchoring of reinforcing metal ribs in end subs, together with the Inflatagrip feature, greatly improves the pressure differential holding ability of the packers.
- Dual inflation valve system provides 56% greater inlet area for the inflation fluid than dual valve systems of competition.
- Longer reinforcing ribs bonded to a rubber cover, in addition to surface preparation of the mandrel, minimize any wadding of packer element during running.
- Premium threads are available internally throughout the packers, eliminating the need for welding or the use of crossover sub.
- No welding or epoxy, which might cause premature failure, is used in manufacturing Davis packers.

Unique Application Large Diameter Inflatagrip Longseal Packers

Davis sales/engineering personnel have designed and implemented a method on several wells in a deepwater-drilling environment, which employs the Inflatagrip Longseal Packers for the purpose of containing troublesome shallow salt-water flows. This system has been utilized on 20" and 16" casing strings at the present time. Packer placement, inflation pressure settings, and the use of specialty float equipment to receive a drop ball have been instrumental in the success of this method. For more complete details please contact your local Davis representative.



Inflatagrip Longseal* Packer
Types 202 and 402

*Patented

©Registered Trademark of Davis-Lynch, LLC U.S. Patent No. 4,829,144

Packers with Continuous Reinforcing

The inflatable element of these packers has steel strips that run from end to end of the seal and are mechanically attached to end subs. Available in standard 3-, 7- and 10-foot lengths, the continuous strip element will centralize the casing in the wellbore and withstand maximum differential pressure. It can be inflated with water, mud or cement. The 7- and 10-foot elements may be preferred for added seal length in fractured or highly permeable zones or where packer placement is critical for success.

The inflatable element consists of an innertube protected by the continuous, mechanically end-anchored, spring-steel reinforcing strips. These strips are totally encased in an oil-resistant outer rubber. Expansion is achieved by injecting fluid into the innertube. The fluid expands the strips, stretching the outer rubber and effecting a full-length seal against the bore wall, in cased or open hole.

Inflatagrip® Feature

When it is desirable for a continuous reinforced packer to act as an anchor, Davis recommends its patented Inflatagrip system, which consists of raised grippers stamped into the steel reinforcing strips. The grippers can be profiled so that, when expanded and in contact with the wellbore, they prevent axial or rotational movement, in either cased or open hole. The grippers are heat treated to a hardness that enables them to bite into P-110 grade casing. The anchoring mechanism can be built into any Davis continuous reinforced packer regardless of diameter.

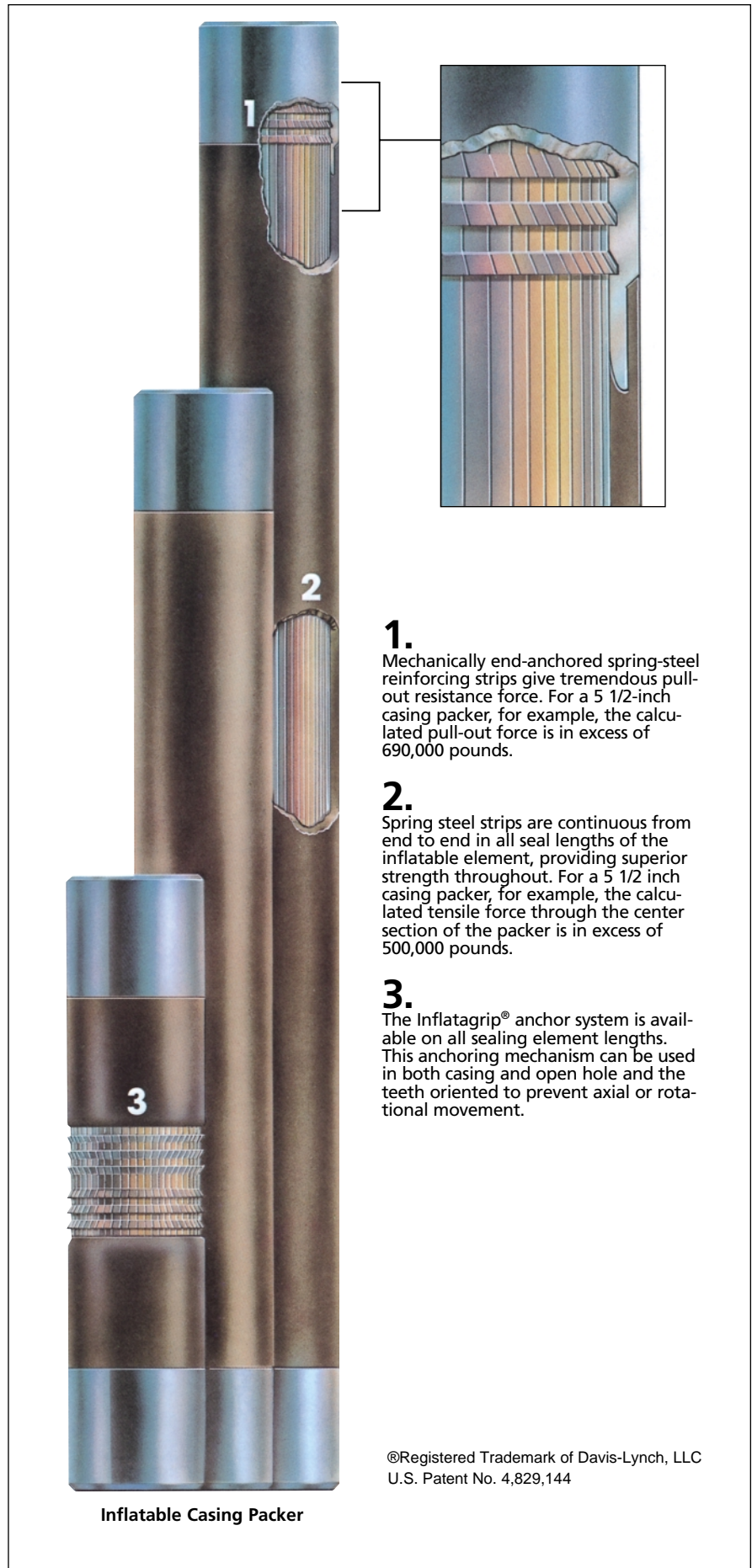

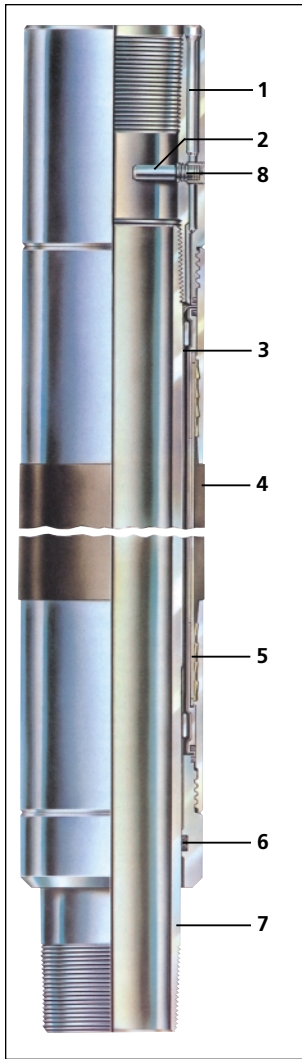

Davis Type 100 Integral Casing Packer

The Type 100 is a permanent, steel-reinforced packer that is run as an integral part of the casing string. The mandrel through the packer is the same size, weight, and grade as the casing. The packer is threaded with connections identical to those of the casing string.

The Integral Casing Packer is available with a single sealing element, or with dual straddle elements. It can be run in a multitude of arrangements for numerous applications. When inflated, the packer element

will effectively seal between concentric casing strings or between casing and open hole.

This packer can be used to:

- Control wellbore migration of gas and fluid.
- Separate multiple zones.
- Prevent unwanted water intrusion.
- Allow gravel packing of multiple zones.
- Reduce hydrostatic pressure during stage cementing.
- Centralize casing.

Type 100 Integral Casing Packer

- | | |
|-----------------------------|-------------------------------|
| 1. Inflation Control Valves | 5. Flexible Steel Reinforcing |
| 2. Knock-Off Plug | 6. Sliding Seal |
| 3. Rubber innertube | 7. Mandrel (Casing Sub) |
| 4. Rubber Outer Cover | 8. Screen |

Packer Selection Table

The Packer Selection Table shows maximum recommended differential pressure across the Integral Casing Packer for any given calipered hole size. For pressure or hole sizes falling between the cited values, the method of interpolation for an approximate value can be used.

The sizes tagged with asterisks are termed "Special Clearance." They are used

where the combination of casing diameter and drilled hole size requires that the diameter of the packer be reduced. These reduced OD sizes are available through special order.

For casing sizes smaller than 3 1/2" and larger than 20", please consult your Davis representative.

Davis Integral Casing Packer Type 100

Nominal Size (Inches)	Diameter of Casing Packer (Inches)	Type No. 100-	Maximum Recommended Differential Pressure (psi) Across Packer in Various Hole Sizes (Inches)						
			1000	1500	2000	2500	3000	3500	4000
3 1/2	4.25	350-425	9.00	8.50	7.50	6.50	5.50	5.25	4.75
4 1/2	5.75	450-575	10.75	10.25	9.75	9.25	8.75	8.25	7.75
4 1/2*	5.63	450-563	9.75	9.00	8.00	7.25	6.75	6.50	6.00
5	6.38	500-638	11.25	10.75	10.25	9.75	9.25	8.75	8.25
5*	6.13	500-613	10.25	9.75	9.25	8.75	8.25	7.50	7.00
5 1/2	7.00	550-700	12.00	11.50	11.00	10.50	10.00	9.50	9.00
5 1/2*	6.75	550-675	11.00	10.50	10.00	9.50	8.50	8.00	7.50
6 5/8	8.00	663-800	13.00	12.50	12.00	11.50	11.00	10.50	10.00
6 5/8*	7.75	663-775	11.25	10.75	10.25	9.75	8.75	8.25	8.00
7	8.25	700-825	13.25	12.75	12.25	11.75	11.25	10.75	10.25
7*	8.06	700-806	12.00	11.00	10.50	10.00	9.00	8.75	8.50
7 5/8	9.00	763-900	14.00	13.50	13.00	12.50	12.00	11.50	11.00
7 5/8*	8.88	763-888	13.00	11.50	11.00	10.50	10.00	9.50	9.25
8 5/8	10.25	863-1025	15.25	14.75	14.25	13.75	13.25	12.75	12.25
9 5/8	11.25	963-1125	16.25	15.75	15.25	14.75	14.25	13.75	13.25
10 3/4	12.75	1075-1275	17.75	17.25	16.75	16.25	15.75	15.25	14.75
13 3/8	15.75	1338-1575	22.25	21.75	21.25	19.75	19.25	18.75	18.25
16	18.00	1600-1800	28.00	26.50	25.00	23.50	22.00	20.50	19.50
18 5/8	20.88	1863-2088	33.00	31.25	29.50	27.75	26.00	24.25	22.50
20	23.00	2000-2300	36.00	34.00	32.00	30.00	28.00	26.00	24.00
22	25.00	2200-2500	30.00	29.00	28.00				

*Special clearance

Davis Fill and Circulate Tool*

The Davis Fill and Circulate (FAC) Tool offers operators the safest and most efficient means to fill or circulate casing strings at desired rates as they are being run. In the fill position, fluid is pumped through the mandrel and the mud saver valve as the casing is being lowered into the well. In the circulate position, the sealing element, slightly larger than the ID of the casing, is lowered into the casing and forms a seal between the FAC Tool and the casing. Pressure applied to the casing for fluid circulation causes the fluid to enter an area behind the sealing element, energizing it to seal against fluid by-pass.

Features of the Davis FAC Tool are:

- Fluid pressure-energized sealing element that is easily inserted into casing, and seals more firmly as pressure increases.
- Tapered aluminum gauge ring below the sealing element protects against thread damage and acts to centralize the tool in the casing.
- Mud-saver valve that retains the static head of the mud and prevents mud from dripping onto the rig floor as tool is being raised into the derrick.
- Flexible steel-reinforced rubber hose with brass guide cone gives added flexibility for inserting the FAC Tool into the casing. Rubber insert on guide cone absorbs impact blows to casing during stabbing, filling, and circulating.
- Reverse flow through the check valve allows any pressure trapped below the FAC Tool to be released prior to removal from casing.

- No “hands-on” manipulation of the FAC Tool is required to change from the fill to the circulate mode, or vice versa.
- The sealing element is easily changed by a single break at the retainer sub.
- The same basic tool body can be

adapted for use with several sizes of casing strings by changing the seal retainer ring, sealing element, and gauge ring.

- Available with optional push-plate feature to aid in running casing to bottom.

*Patented

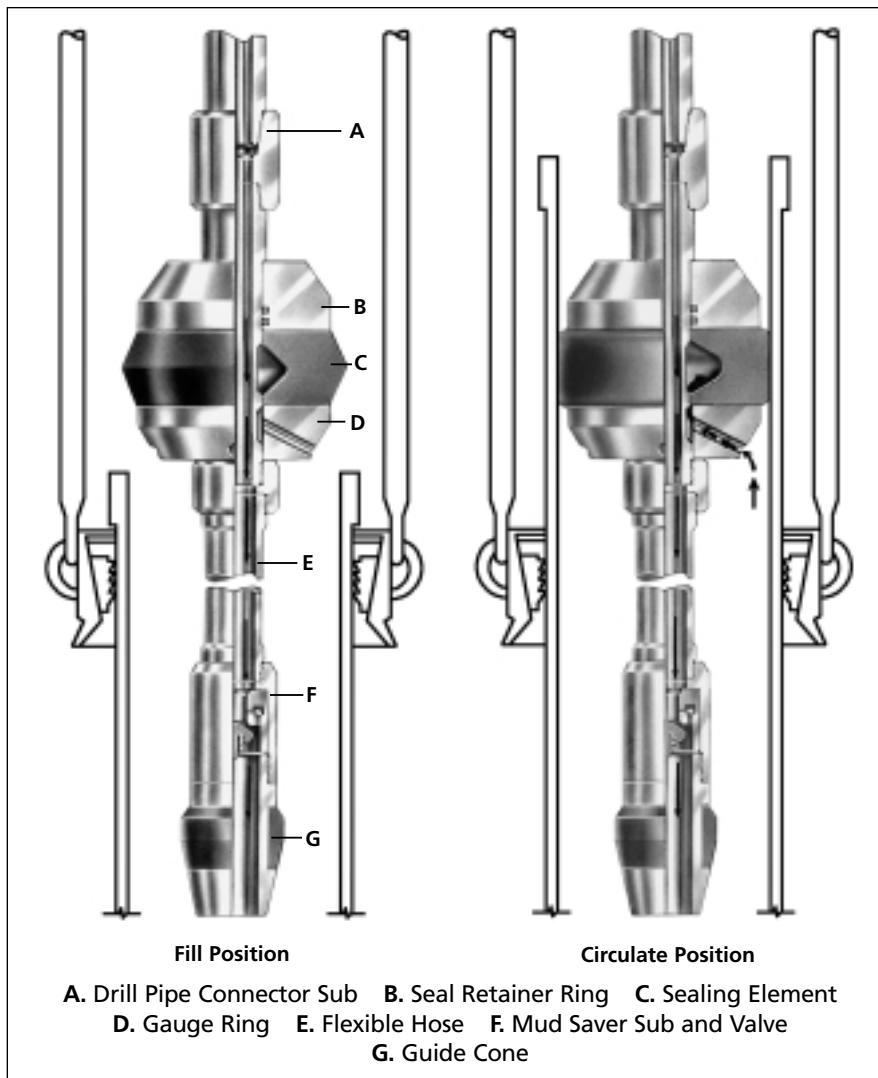

Fill and Circulate (FAC) Tool Available Sizes

Casing Size (Inches)	Casing Weights (Lbs/ft)	Casing Size (Inches)	Casing Weights (Lbs/ft)
4 1/2	11.60, 12.60, 13.50	10 3/4	40.5, 45.5, 51, 55.5
5	15, 18, 20.3	11 3/4	47, 54, 60, 65, 66.7, 71
5 1/2	15.5, 17, 20, 23	11 7/8	71.8
7	17, 20, 23, 26, 29, 32	13 3/8	54.5, 61, 68, 72, 77
7 5/8	24, 26.4, 29.7, 33.7, 39, 42.8	13 5/8	88.2
7 3/4	46.1	16	65, 75, 84, 94, 109
8 5/8	24, 28, 32, 36	18 5/8	87.5, 94.5, 97.7, 106, 117.5
9 5/8	40, 43.5, 47, 53.5	20	94, 106.5, 131, 133, 163
9 7/8	62.8		

Other sizes not listed above available on request

Davis

DAVIS-LYNCH, LLC

Box 262326
Houston, Texas 77207-2326
24 Hours: 281-485-8301
Fax: 281-485-6814
International Fax: 281-485-9836
E-mail: davis@davis-lynch.com
Website: www.davis-lynch.com

For a complete list of worldwide representatives
and distribution locations, please visit our website
or contact our headquarters in Houston, Texas